

OFF VEHICLE CARBURETOR SERVICE AISAN A-1 (TOYOTA TERCEL 1987-90)

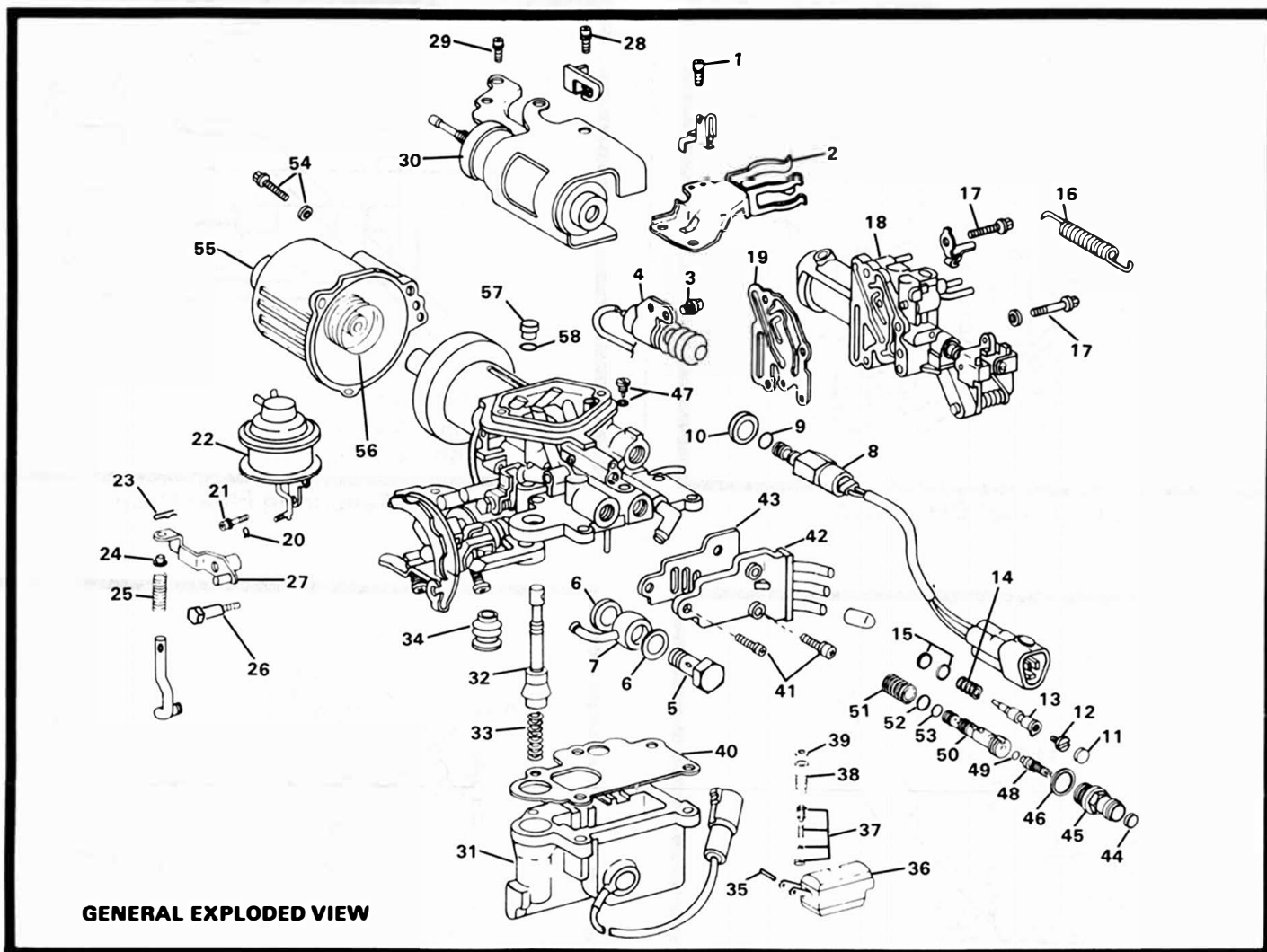

GENERAL EXPLODED VIEW

DISASSEMBLY

USE THE EXPLODED VIEW AS A GUIDE. THE NUMERICAL SEQUENCE MAY GENERALLY BE FOLLOWED TO DISASSEMBLE UNIT FAR ENOUGH TO PERMIT CLEANING AND INSPECTION. NOTE SPECIAL INSTRUCTIONS.

SPECIAL DISASSEMBLY INSTRUCTIONS

BEFORE BEGINNING DISASSEMBLY OF CARBURETOR, CAREFULLY NOTE LOCATION OF WIRING AND BRACKETS FOR COMPONENTS. THEN LOCATE AND TAG ALL VACUUM HOSES. TURN MIXTURE ADJUSTMENT SCREW (12) IN UNTIL LIGHTLY SEATED, AND RECORD NUMBER OF TURNS. PART #15, WASHER WITH RUBBER BONDING, IS REPLACED IN KIT BY A SEPARATE METAL WASHER AND RUBBER DISC. REMOVE PLUG (44) AND TURN 1st THROTTLE ADJUSTING SCREW (4B) OUT (CCW) UNTIL LIGHTLY SEATED, RECORD NUMBER OF TURNS. DO NOT DISASSEMBLE COMPENSATOR OR THROTTLE SHAFT ASSEMBLY UNLESS REPLACEMENT IS NECESSARY. REMOVAL OF SUCTION PISTON ASSEMBLY IS NOT RECOMMENDED UNLESS REPLACEMENT IS REQUIRED.

CLEANING

CLEANING MUST BE DONE WITH UNIT DISASSEMBLED. DO NOT IMMERSE ANY COMPONENT CONTAINING PLASTIC OR ELECTRICAL PARTS IN ANY TYPE OF CLEANING SOLVENT. DAMAGE TO THE COMPONENTS WILL RESULT. CLEAN PASSAGES AND PARTS WITH A SPRAY CARBURETOR CLEANER. BE SURE TO REMOVE ALL CARBON DEPOSITS. WASH OFF WITH SUITABLE SOLVENT AND USE COMPRESSED AIR TO BLOW OUT ALL PASSAGES. DO NOT USE SOLVENT OR CLEANER ON ANY ELECTRICAL PARTS.

REASSEMBLY

REASSEMBLE IN REVERSE ORDER OF DISASSEMBLY. NOTE ALL SPECIAL REASSEMBLY INSTRUCTIONS.

SPECIAL REASSEMBLY INSTRUCTIONS

USING A LIGHT MACHINE OIL, LIGHTLY LUBRICATE ALL O-RINGS BEFORE INSTALLATION. MIXTURE ADJUSTMENT SCREW (12) AND 1st THROTTLE ADJUSTING SCREW (4B)-TURN TO LIGHTLY SEAT. BACK OUT NUMBER OF TURNS RECORDED ON DISASSEMBLY. THROTTLE ADJUSTING SCREW (4B)-TURN OUT TO LIGHTLY SEAT. TURN IN NUMBER OF TURNS RECORDED ON DISASSEMBLY. RELOCATE WIRING AND BRACKETS AS NOTED. REPOSITION VACUUM HOSES AS NOTED AND TAGGED.

NOMENCLATURE

REF. NO.	REF. NO.
1. SCREW & WASHER, FLOAT BOWL WITH BRACKETS, 2	30. THROTTLE VALVE SOLENOID
2. BRACKET	31. FLOAT BOWL WITH HEATER
3. SCREW & WASHER, IDLE SWITCH, 2	32. ACCELERATOR PUMP
4. IDLE SWITCH	33. SPRING, ACCELERATOR PUMP
5. BOLT, FUEL INLET FITTING	34. BOOT, ACCELERATOR PUMP
6. WASHERS, FUEL INLET FITTING, 2	35. PIN, FLOAT
7. FUEL INLET FITTING	36. FLOAT
8. THROTTLE POSITION SWITCH	37. NEEDLE VALVE
9. WASHER, THROTTLE POS. SWITCH	38. SEAT, NEEDLE VALVE
10. O-RING, THROTTLE POSITION SWITCH	39. WASHER, NEEDLE VALVE
11. COVER, MIXTURE ADJUST. SCREW	40. GASKET, FLOAT BOWL
12. SCREW, MIXTURE ADJUSTMENT	41. SCREW & WASHER, VACUUM ADAPTOR, 3 (Note location of long screw)
13. PLUNGER, MIXTURE ADJUSTMENT	42. VACUUM ADAPTOR
14. SPRING, MIXTURE ADJUSTMENT	43. GASKET, VACUUM ADAPTOR
15. WASHER W/RUBBER DISC BONDED	44. PLUG, THROTTLE ADJUST. SCREW
16. SPRINGS, COMPENSATOR RETURN	45. SCREW & WASHER, COMPENSATOR ASSEMBLY, 3 (Note position of longer screw)
17. SCREW & WASHER, COMPENSATOR ASSEMBLY, 3	46. WASHER, MAIN PASSAGE
18. COMPENSATOR ASSEMBLY	47. PIN, 1st MAIN JET WITH WASHER
19. GASKET, COMPENSATOR	48. SCREW, THROTTLE ADJUSTING
20. KEEPER, THROTTLE POSITIONER	49. O-RING, THROTTLE ADJUST. SCREW
21. SCREW & WASHER, THROTTLE POSITIONER, 2	50. 1st MAIN JET
22. THROTTLE POSITIONER	51. SPRING, MAIN JET
23. KEEPER, ACCELERATOR PUMP LEVER	52. O-RING, MAIN JET GUIDE
24. BUSHING, ACCEL. PUMP LEVER	53. O-RING, SLOW JET
25. SPRING, ACCELERATOR PUMP LEVER	54. SCREW & WASHER, SUCTION CHAMBER, 3
26. BOLT, ACCELERATOR PUMP LEVER	55. COVER, SUCTION CHAMBER
27. ACCELERATOR PUMP LEVER	56. SPRING, SUCTION CHAMBER
28. SCREW & WASHER, FLOAT BOWL, W/BRACKET ON SOLENOID, 2	57. PLUG, SUCTION CHAMBER
29. SCREW, THROTTLE VALVE SOLENOID, 1	58. O-RING, SUCTION CHAMBER

ADJUSTMENTS FOR AISAN A-1 (TOYOTA TERCEL 1987-90)

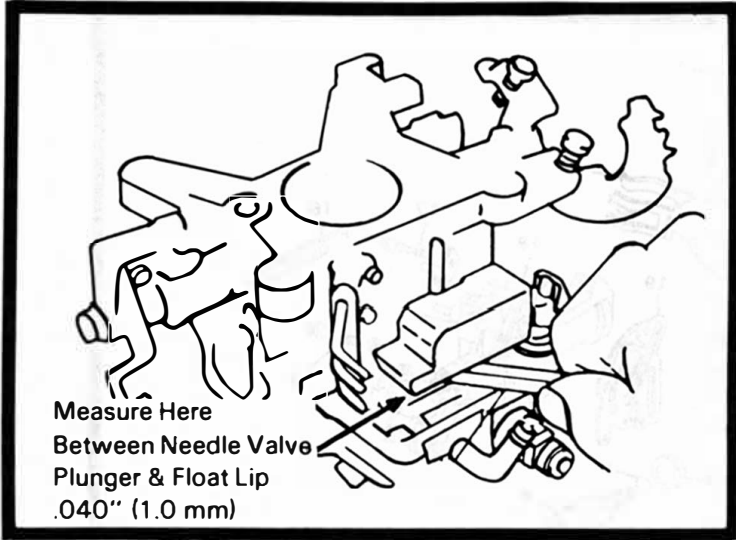

Measuring Float Clearance

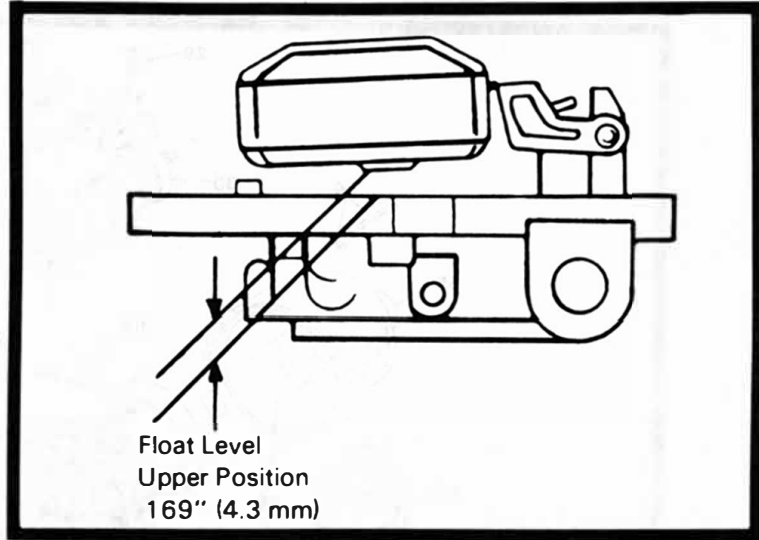

Measuring Float Drop

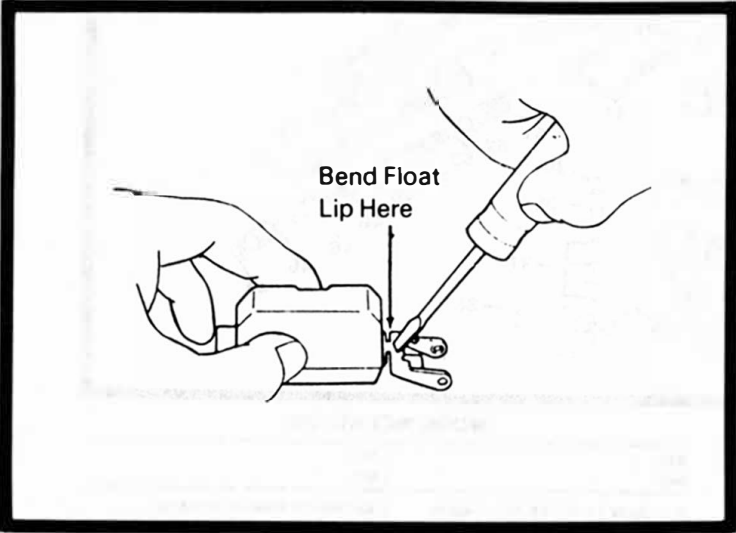

Bending Float Lip

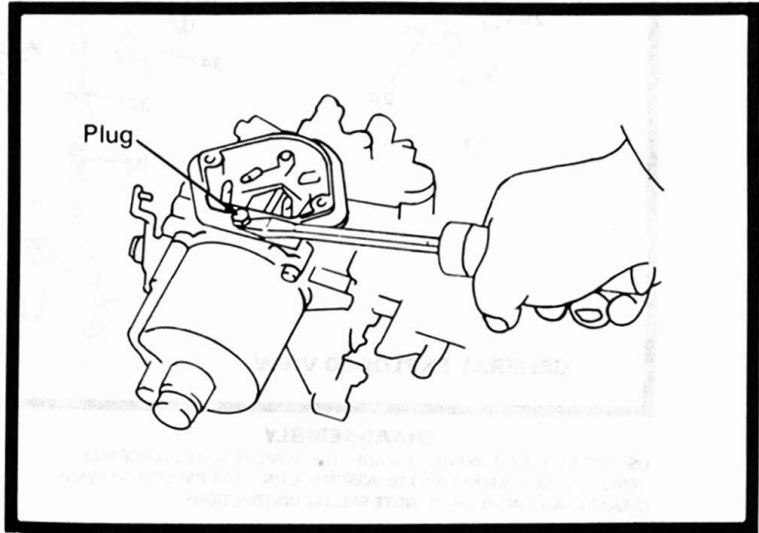

Removing Suction Chamber Adjusting Pin

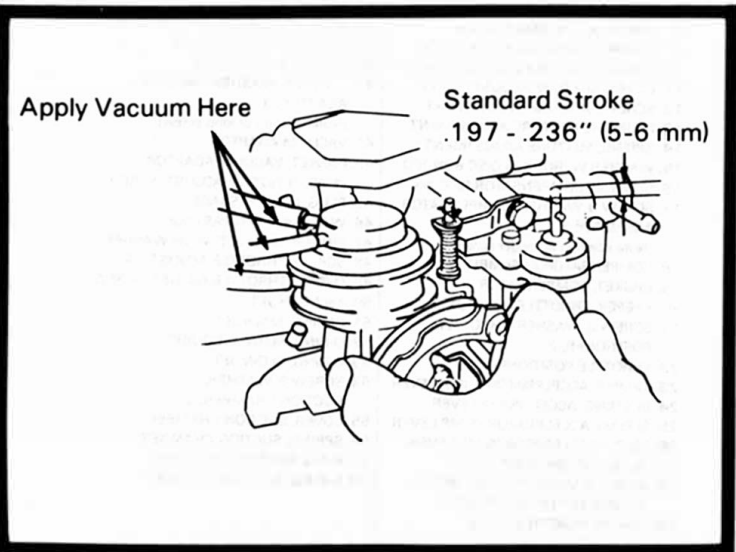

Checking Pump Stroke

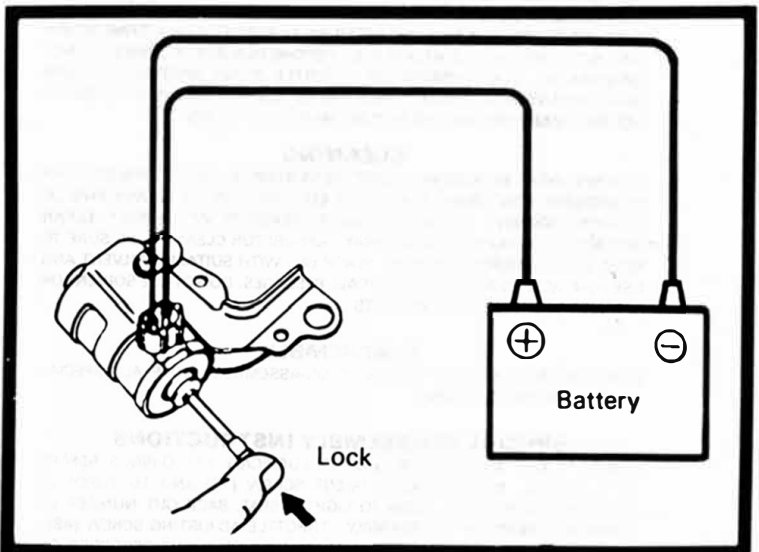

Checking Throttle Valve Solenoid