

INSTRUCTION SHEET

CARTER CARBURETOR - MODEL YF

USE WITH 50-563-1

50-732

GENERAL EXPLODED VIEW

THE GENERAL DESIGN AND PARTS SHOWN WILL VARY TO INDIVIDUAL UNITS COVERED ON THIS INSTRUCTION SHEET.

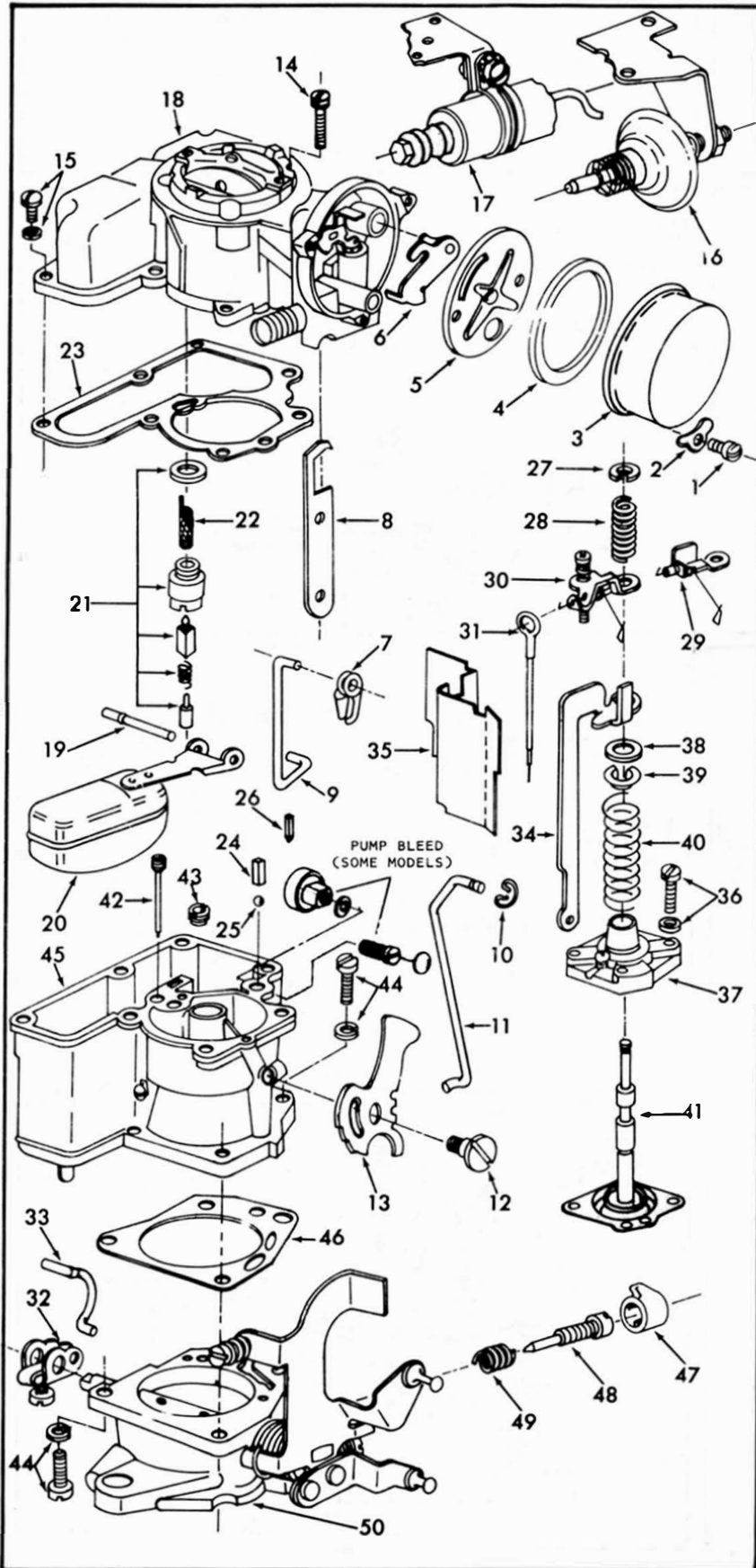

DISASSEMBLY

USE EXPLODED VIEW AS A GUIDE. THE NUMERICAL SEQUENCE MAY GENERALLY BE FOLLOWED TO DISASSEMBLE UNIT FAR ENOUGH TO PERMIT CLEANING AND INSPECTION. NOTE: TO REMOVE PLASTIC LIMITER CAP (47) INSTALL A SHEET METAL SCREW IN THE CENTER OF THE CAP AND TURN CLOCKWISE.

NOMENCLATURE

REF. NO.	REF. NO.
1. SCREW(3)-CHOKE COVER CLAMP	25. BALL-PUMP CHECK
2. CLAMP(?) -CHOKE COVER	26. NEEDLE-PUMP CHECK (SOME MODELS)
3. CHOKE COVER & SPRING	27. RETAINER-UPPER PUMP SPRING
4. GASKET-CHOKE COVER	28. SPRING-UPPER PUMP
5. BAFFLE PLATE-CHOKE	29. ARM ASSY.-METERING ROD (EARLY MODELS)
6. TRIP LEVER-CHOKE	30. ARM & ADJ. SCREW ASSY.-METERING ROD
7. RETAINER-FAST IDLE LINK (EARLY MODELS)	31. ROD-METERING
8. LINK-FAST IDLE (EARLY MODELS)	32. ARM-THROTTLE SHAFT
9. ROD-FAST IDLE (EARLY MODELS)	33. LINK-PUMP CONNECTOR
10. RETAINER-FAST IDLE ROD	34. LINK-PUMP LIFTER
11. ROD-FAST IDLE	35. BAFFLE PLATE-FUEL BOWL (SOME MODELS)
12. SCREW-FAST IDLE CAM	36. SCREW & LOCKWASHER(4)-PUMP HOUSING
13. CAM-FAST IDLE	37. PUMP HOUSING ASSEMBLY
14. SCREW & LOCKWASHER(3)-LONG-BOWL COVER	38. SPACER-PUMP STEM (SOME MODELS)
15. SCREW & LOCKWASHER(4) SHORT-BOWL COVER	39. RETAINER-PUMP SPRING
16. OASHPOT & BRACKET-(WHEN USED)	40. SPRING-PUMP
17. SOLENOID & BRACKET-(WHEN USED)	41. PUMP DIAPHRAGM ASSEMBLY
18. BOWL COVER ASSEMBLY	42. JET-LOW SPEED
19. PIN-FLOAT	43. JET-METERING ROD
20. FLOAT & LEVER ASSEMBLY	44. SCREW & LOCKWASHER(3)-THROTTLE BODY
21. NEEDLE, SEAT AND GASKET ASSEMBLY	45. BOWL ASSEMBLY
22. SCREEN-NEEDLE SEAT (SOME MODELS)	46. GASKET-THROTTLE BODY
23. GASKET-BOWL COVER	47. CAP-IDLE LIMITER
24. WEIGHT-CHECK BALL	48. NEEDLE-IDLE ADJUSTING
	49. SPRING-IDLE NEEDLE
	50. THROTTLE BODY ASSEMBLY

CLEANING

CLEANING MUST BE DONE WITH CARBURETOR DISASSEMBLED. USE A CARBURETOR CLEANING SOLVENT TO SOAK PARTS LONG ENOUGH TO SOFTEN AND REMOVE ALL FOREIGN MATERIAL. MAKE CERTAIN THE THROTTLE BORE IS FREE OF ALL CARBON AND VARNISH DEPOSITS. RINSE OFF IN SUITABLE SOLVENT. BLOW OUT ALL PASSAGES IN CASTINGS WITH COMPRESSED AIR AND CHECK CAREFULLY TO INSURE THOROUGH CLEANING TO OBSCURE AREAS. CAUTION: DO NOT SOAK PARTS CONTAINING RUBBER MATERIALS. SUCH AS (3)(16)(17)(41).

REASSEMBLY

REASSEMBLE IN REVERSE ORDER OF DISASSEMBLY. NOTE: SPECIAL INSTRUCTIONS AND FOLLOW NUMERICAL OUTLINE IN MAKING ADJUSTMENTS NECESSARY FOR CARBURETOR BEING SERVICED.

SPECIAL INSTRUCTIONS

IDLE ADJUSTING NEEDLE (48)-TURN IN UNTIL LIGHTLY SEATED, THEN BACK OUT 1 1/2 TURNS.

PUMP DIAPHRAGM INSTALLATION (41)-INSERT DIAPHRAGM (41) IN HOUSING (37) AND ALIGN HOLES. INSERT SCREWS THROUGH HOUSING AND DIAPHRAGM. INSTALL SPRING (40) AND RETAINER (39). PLACE IN CARBURETOR START SCREWS THEN COMPRESS DIAPHRAGM, HOLDING IN THIS POSITION TIGHTEN SCREWS.

FLOAT PIN (19)-INSTALL WITH SHOULDER ON PIN AWAY FROM PUMP DIAPHRAGM STEM.

CARBURETOR HOLD DOWN NUTS.-TORQUE TO 14 FT. LBS.

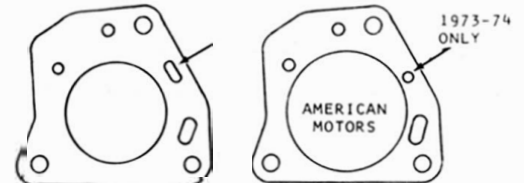

THROTTLE BODY GASKET (46)-IDENTIFICATION.

ADJUSTMENTS

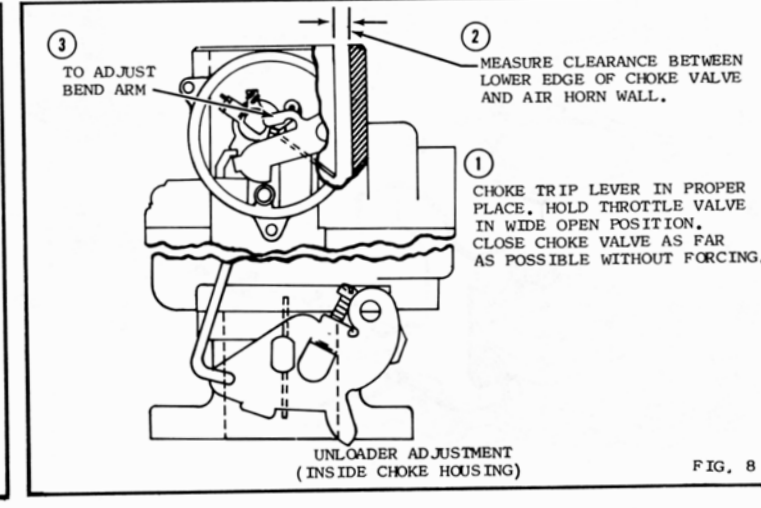
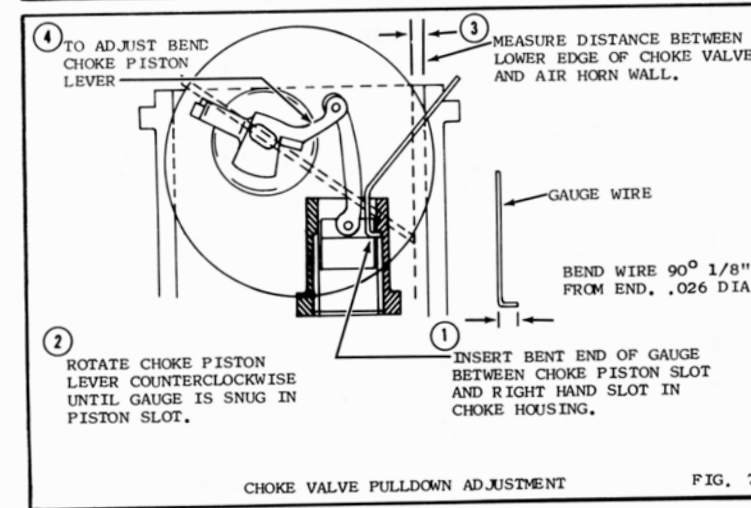
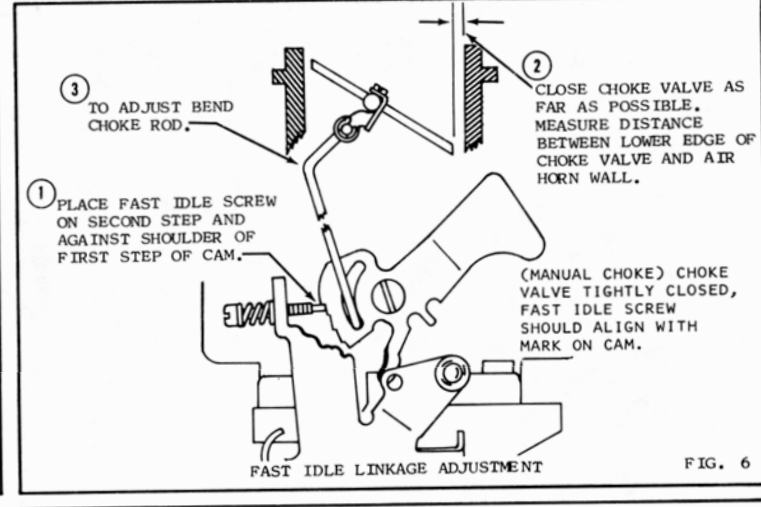
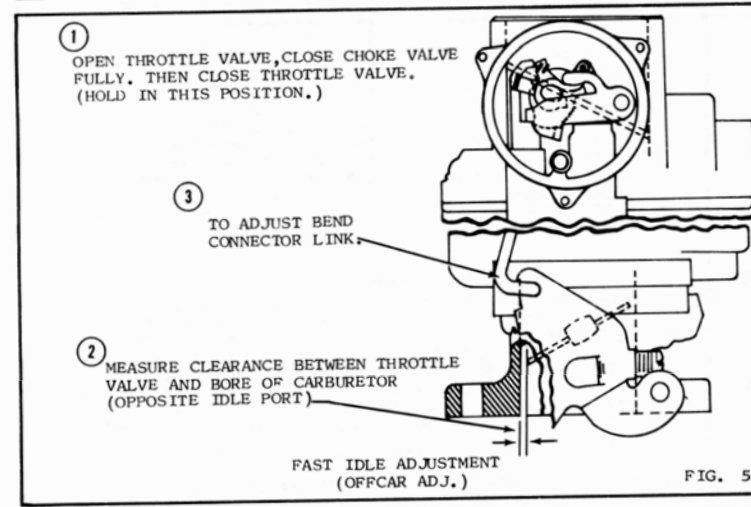
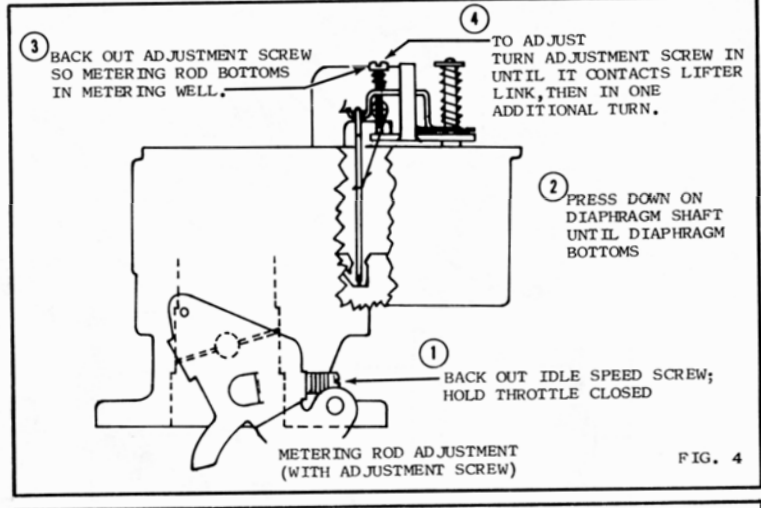
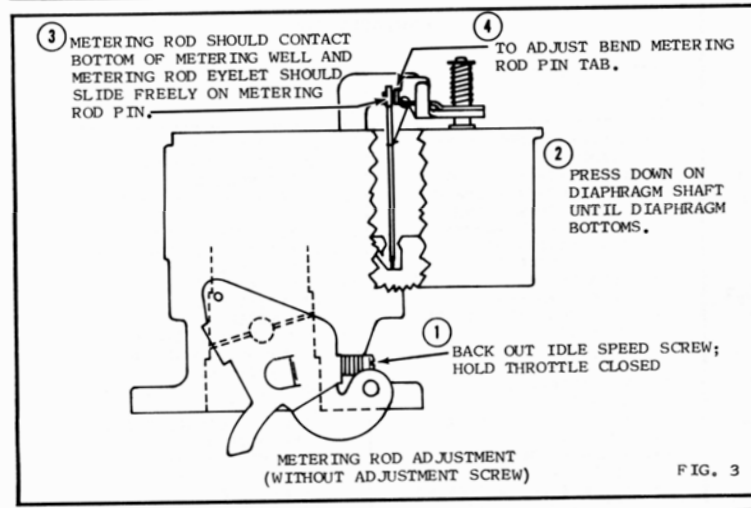
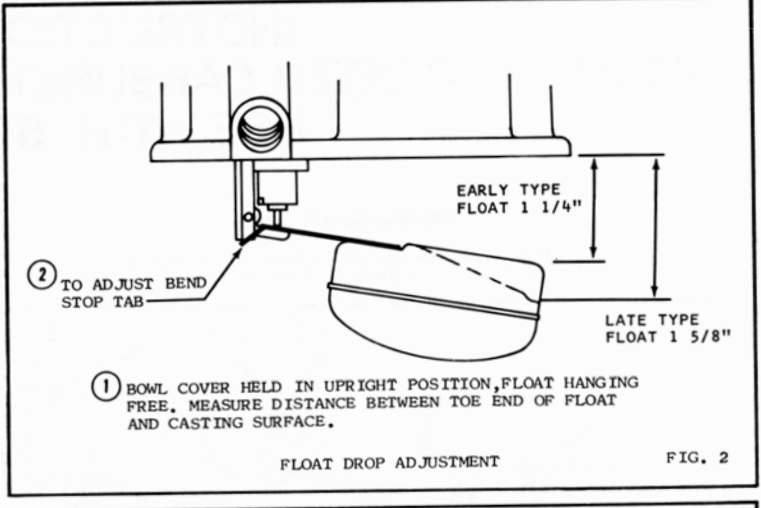
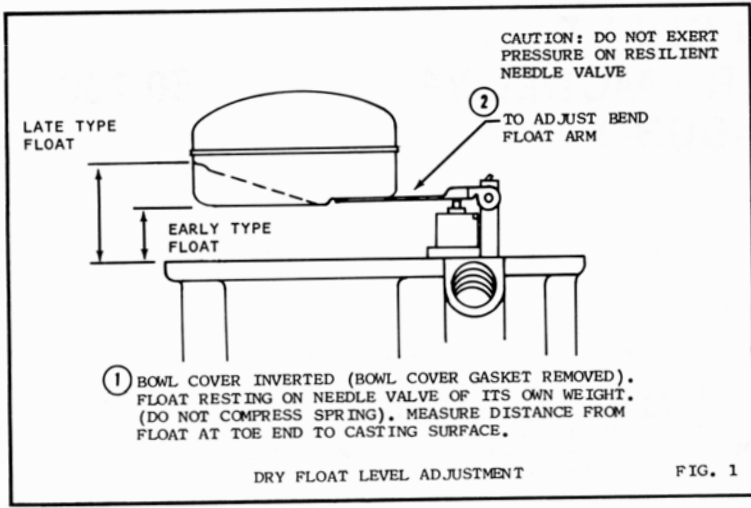

ADJUSTMENTS

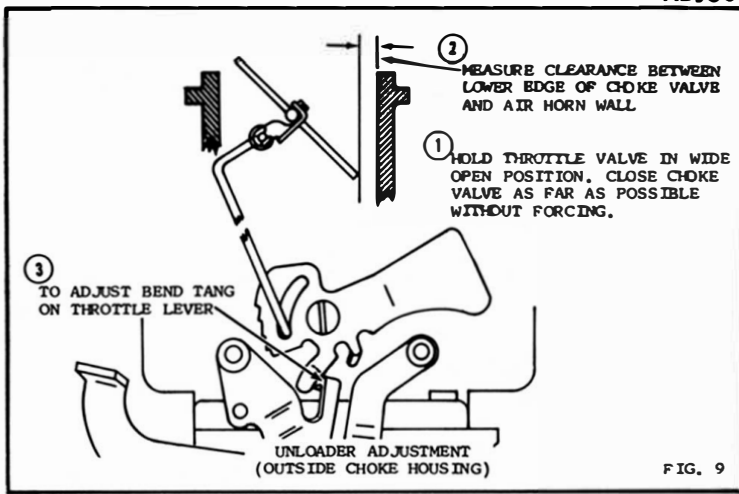
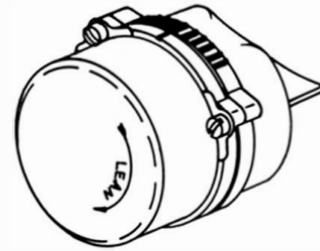

FIG. 9

ROTATE CHOKE COVER TO ALIGN REFERENCE MARK ON COVER TO SPECIFIED POINT ON CHOKE HOUSING.



AUTOMATIC CHOKE ADJUSTMENT

FIG. 10

USE FACTORY CAR MANUAL PROCEDURE FOR SETTING SLOW IDLE IF AVAILABLE, AND SPECIFICATIONS LISTED ON ENGINE DECAL.

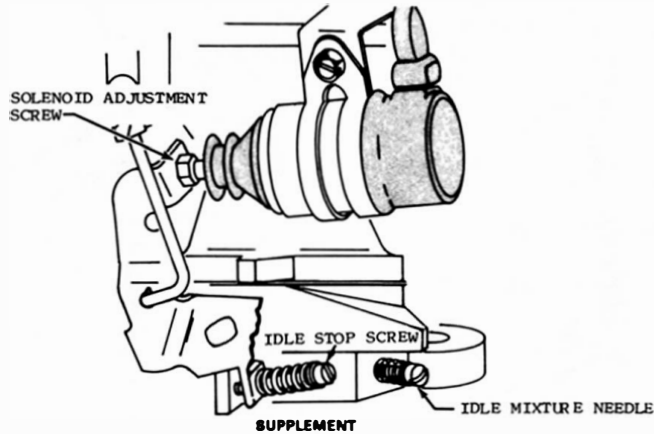

SLOW IDLE ADJUSTMENT WITH AND WITHOUT THROTTLE POSITIONER.

1. SET IGNITION TIMING PER CAR FACTORY SPECIFICATIONS AND PROCEDURE.
2. ENGINE AT OPERATING TEMPERATURE, CHOKE FULLY OPEN. A. HEADLIGHTS ON, HIGH BEAM. B. AUTOMATIC TRANSMISSION IN DRIVE.
3. ADJUST THROTTLE STOP SCREW TO SPECIFIED IDLE SPEED R.P.M. USING A TACHOMETER. NOTE: WHEN USED, ADJUST SOLENOID THROTTLE POSITIONER TO SPECIFIED IDLE SPEED. (SOLENOID LEAD MUST BE CONNECTED SO SOLENOID WILL BE ENERGIZED.)
4. AIR CLEANER INSTALLED
5. ADJUST IDLE MIXTURE NEEDLE TO OBTAIN THE HIGHEST R.P.M. AT THE LEANEST BEST IDLE SETTING.
6. READJUST IDLE SPEED IF NECESSARY. NOTE: DISCONNECT SOLENOID THROTTLE POSITIONER AT BULLET CONNECTION THEN ADJUST THROTTLE STOP SCREW FOR LOWER R.P.M. WITH AUTOMATIC OR MANUAL TRANSMISSIONS IN NEUTRAL. CONNECT SOLENOID, OPEN THROTTLE AND RELEASE. RECHECK HIGHER IDLE SPEED.

SLOW IDLE ADJUSTMENT

FIG. 11

NOTE: VEHICLES EQUIPPED WITH A SPARK DELAY DEVICE AND WITH AMBIENT TEMPERATURE ABOVE 55°F. BEFORE SETTING FAST IDLE SPEED.

A. CONNECT VACUUM LINE DIRECTLY FROM THE CARBURETOR SPARK PORT TO THE ADVANCE SIDE OF THE DISTRIBUTOR.

B. DISCONNECT THE VACUUM SUPPLY LINE TO THE EGR VALVE AND PLUG THE LINE.

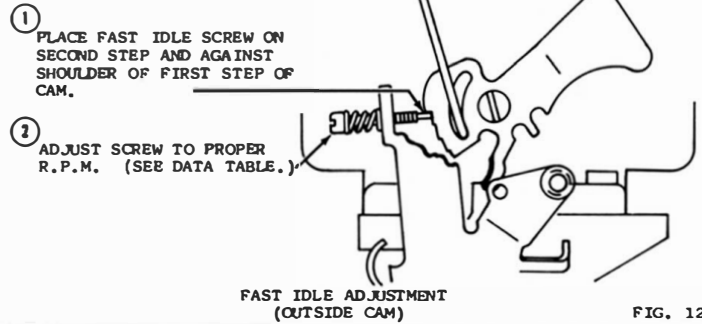

FIG. 12

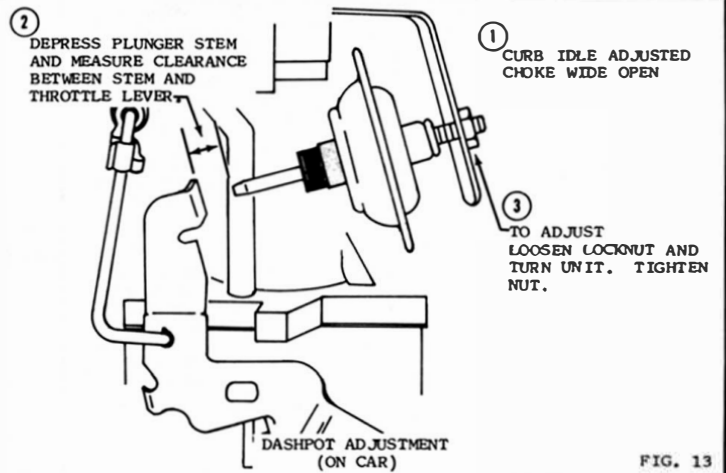

FIG. 13

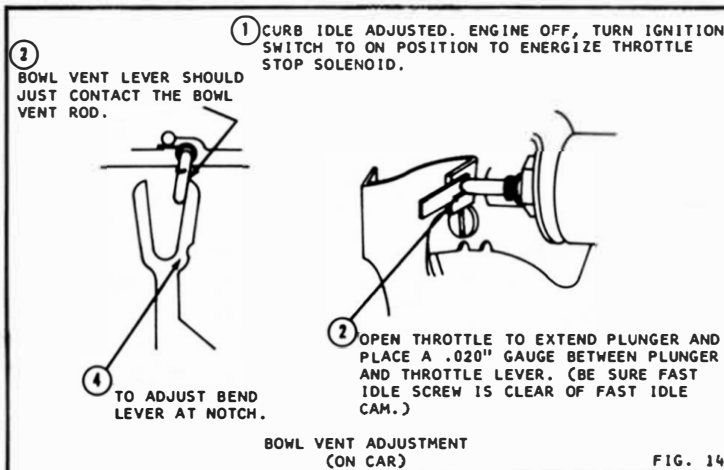
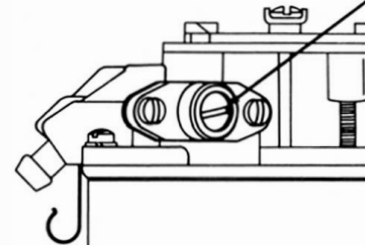

FIG. 14

WHERE THE ALTITUDE COMPENSATOR VALVE CARBURETOR IS USED, THE COMPENSATOR SCREW SHOULD BE CLOSED AT SEA LEVEL OPERATION AND OPENED BY TURNING COUNTER CLOCKWISE FOR ALTITUDE OPERATION.



ALTITUDE ADJUSTMENT

FIG. 15