

# INSTRUCTION SHEET

## CARTER AUTOMOTIVE 9000 SERIES MODEL AFB

### DISASSEMBLY

The numerical sequence of the exploded view may be used as a guide to disassemble unit far enough to permit cleaning, inspection and installation of kit contents. Notice the holes from which linkage rods are removed so they can be returned to the same locations during reassembly. **CAUTION:** If choke or throttle shaft requires removal, the attaching valve screws are staked over and the staking must be filed off before screws are turned.

### CLEANING

Clean all parts in an approved cleaning solvent. Special attention should be given to carbon deposits in throttle bore and passages. Rinse parts in suitable solvent. Blow out all passages with compressed air. Do not soak leather, rubber or similar material in solvent.

### REASSEMBLY

Reverse the numerical sequence using reference numbers shown in exploded view as a guide and note the following special instructions:

1. Idle mixture screw (43) should be seated lightly and then backed out two turns for the initial setting. Refer to manufacturer's service manual for proper idle and fast idle final adjustment on the engine.
2. Vacuum piston springs (6), vacuum piston (5) and metering rod assemblies (3, 4) should be installed after bowl cover (20) has been attached to body.
3. Mark venturi assemblies (30, 34) before removal so they can be reinstalled in their proper location.
4. Be sure the fuel baffles on the bowl cover slide down in front of baffle plates (28) in fuel bowl.
5. Install open end of "S" link (14) toward choke valve. Link should read "S" from front of carb.
6. When installing bowl cover (20), guide brass bleed tubes on primary venturi through the bowl cover.
7. Apply a light film of lubricant to cup of plunger assembly (25) before installing.
8. After completion of all adjustments, be sure throttle valves move freely from wide open to closed position.

### GENERAL EXPLODED VIEW

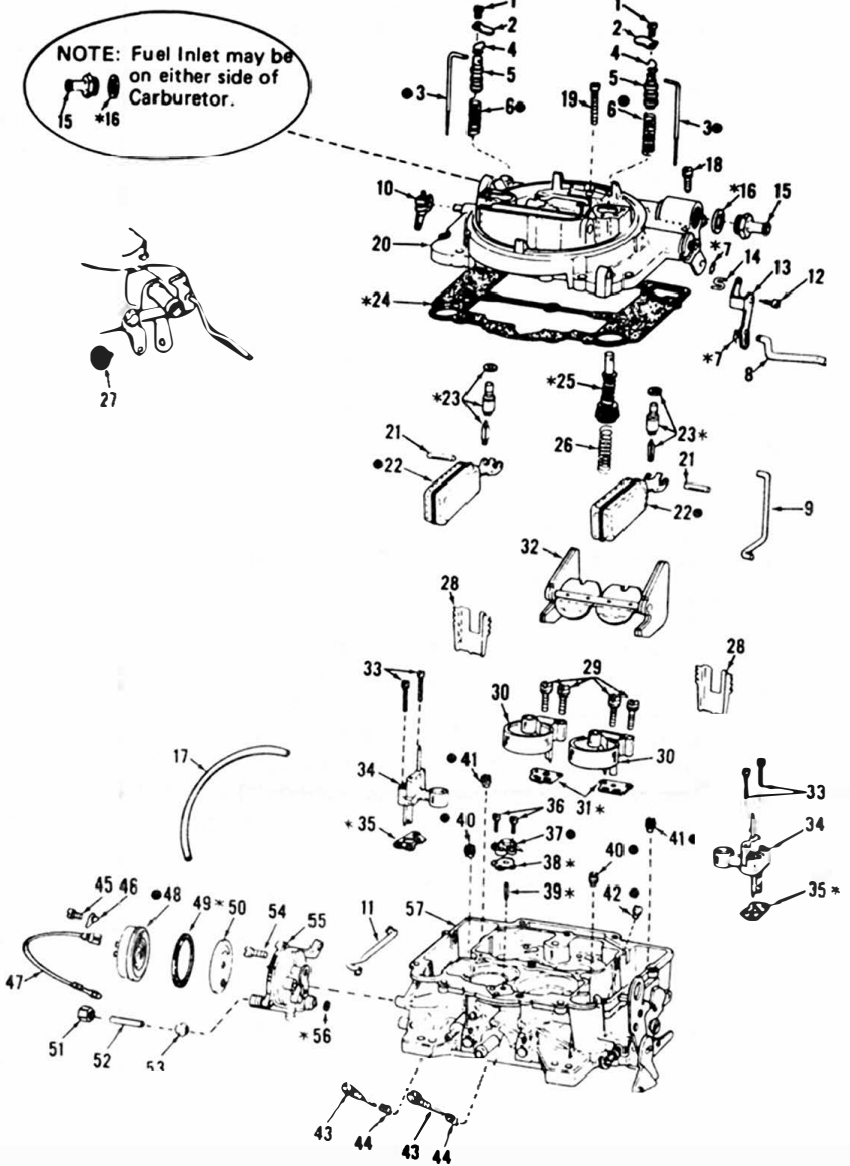

### NOMENCLATURE

1. Cover plate screw	(2)	22. Float	(2)	43. Idle mixture screw	(2)
2. Cover plate	(2)	23. Needle and seat assembly	(2)	44. Idle mixture screw spring	(2)
3. Step-up rod	(2)	24. Bowl cover gasket		45. Coil housing retainer screw	(3)
4. Step-up rod retainer spring	(2)	25. Plunger assembly		46. Coil housing retainer	(3)
5. Step-up piston	(2)	26. Lower plunger spring		47. Choke ground wire (black)	
6. Vacuum piston spring	(2)	27. Vent valve		48. Coil housing	
7. Pin spring	(2)	28. Float bowl baffle	(2)	49. Coil housing gasket	
8. Pump connector rod		29. Secondary venturi assy. screw	(4)	50. Baffle plate	
9. Fast idle cam connector rod		30. Secondary venturi assembly	(2)	51. 1/4" Compression nut	
10. Countershaft lever		31. Secondary venturi assy. gasket	(2)	52. 1/4" Fresh air choke tube	
11. Choke connector rod		32. Auxiliary valves and shaft		53. 1/4" Compression ferrule	
12. Pump lever screw		33. Primary venturi assembly screw	(4)	54. Piston housing attaching screw	(3)
13. Pump lever		34. Primary venturi assembly	(2)	55. Piston housing	
14. Pump "S" link		35. Primary venturi assembly gasket	(2)	56. Piston housing gasket	
15. Fuel inlet fitting		36. Pump jet housing screw	(2)	57. Throttle body casting	
16. Fuel inlet fitting gasket		37. Pump jet housing			
17. 3/16" Fresh air choke hose		38. Pump jet gasket			
18. Bowl cover screw	(8)	39. Pump discharge check needle			
19. Bowl cover screw	(2)	40. Primary metering jet	(2)		
20. Bowl cover		41. Secondary metering jet	(2)		
21. Float pin	(2)	42. Pump intake check jet			

# ADJUSTMENTS

## FLOAT LEVEL (FIG. 1)

With bowl cover inverted, bowl cover gasket in place, and weight of float seating needle, there should be 5/16 inch between top of each float and bowl cover gasket (at outer end.) The sides of floats should be parallel to the outer edge of the bowl cover. To adjust bend float lever. **CAUTION! DO NOT PRESS NEEDLE INTO SEAT WHEN ADJUSTING FLOAT LEVER.**

## FLOAT DROP (FIG. 2)

With bowl cover held in upright position adjust stop tab on float brackets to obtain 15/16 inch between outer end of each float and air horn gasket. To adjust bend tab on float lever.

## PUMP (FIG. 3)

Back out throttle speed screw to allow throttle valves to seat in bores. Install connector rod in bottom hole of pump lever. Adjust rod to obtain 15/32 inch (Except 9637 use 13/32), from top of bowl cover to top of plunger stem as shown.

## CHOKE PISTON LINKAGE (FIG. 4)

Open the choke valve and insert a .026 wire (bend 90° 1/8" from end) between top of slot in choke piston cylinder and bottom of the slot in the piston. Hold wire in position and close choke valve by pressing on piston lever (A) until resistance is felt. The dimension (C) should be (9400—3/64) (9500, 9501, 9510, 9511, 9625, 9635—7/64) (9626, 9636—3/32) (9627, 9637—1/16) inch between the top edge of choke valve and wall of air horn. To adjust, move clamplever (B—early models) or bend link (D—late models).

## FAST IDLE LINKAGE (FIG. 5)

Place fast idle screw (A) on second step of cam. Move choke valve toward the closed position as far as possible without forcing. The dimension (C) should be 3/64 inch (9510, 9635—1/16) (9626, 9637—5/64) between the upper edge of choke valve and wall of air horn. To adjust bend rod (D).

## SECONDARY THROTTLE LOCK OUT (FIG. 6)

Crack throttle valves and manually open and close the choke valve. Tang on secondary throttle should freely engage in notch of lock out dog. To adjust bend tang on secondary throttle lever.

## SECONDARY THROTTLE VALVE OPENING (FIG. 7)

Secondary throttle valves should just start to open when there is 11/32 inch between primary throttle valve and bore of carburetor as shown to adjust bend rod (A). With primary throttle valves wide open adjust stop tang (B) until secondary valves are 5° before full vertical position.

## SECONDARY THROTTLE VALVE CLOSING (FIG. 8)

With primary and secondary throttle valves tightly closed, there should be .020 clearance between levers as shown. To adjust bend shoe on lever (A).

## UNLOADER (FIG. 9)

With throttle valves open, close choke valve as far as possible without forcing. The dimension (C) between top edge of choke valve and inner wall of air horn should be 1/4 inch. To adjust, bend tang (D) on throttle lever.

## ELECTRIC CHOKE SETTING (FIG. 10)

Rotate cover against spring tension until mark on thermostat cover is aligned with index mark on housing. Turn clockwise an additional two notches rich (9627, 9637—3 notches rich) for proper setting.

## BOWL VENT (FIG. 11)

Remove plug (A) from hole in airhorn and insert a narrow ruler. Allow ruler to rest lightly on top of valve. With throttle valves closed and choke open, the dimension from the top of the valve to top of hole in casting should be 3/4 inch. To adjust bend valve operating lever (B).

## NEEDLE AND SEAT ASSEMBLY (FIG. 12)

Early AFB's use rubber-tipped needles with solid bodies and a screen at the inlet fitting. Later AFB's use spring-loaded needles and screens fitted to the seat body. Both types are in this kit. Use the one duplicating original parts. Float setting for both styles is 5/16" (+/- 1/64").

