

# INSTRUCTION SHEET

## OFF VEHICLE CARBURETOR SERVICE

### HITACHI-MODEL DCR384

ISUZU P'UP-1986

#### GENERAL EXPLODED VIEW

THE GENERAL DESIGN AND PARTS SHOWN WILL VARY TO  
INDIVIDUAL UNITS COVERED ON THIS INSTRUCTION SHEET.

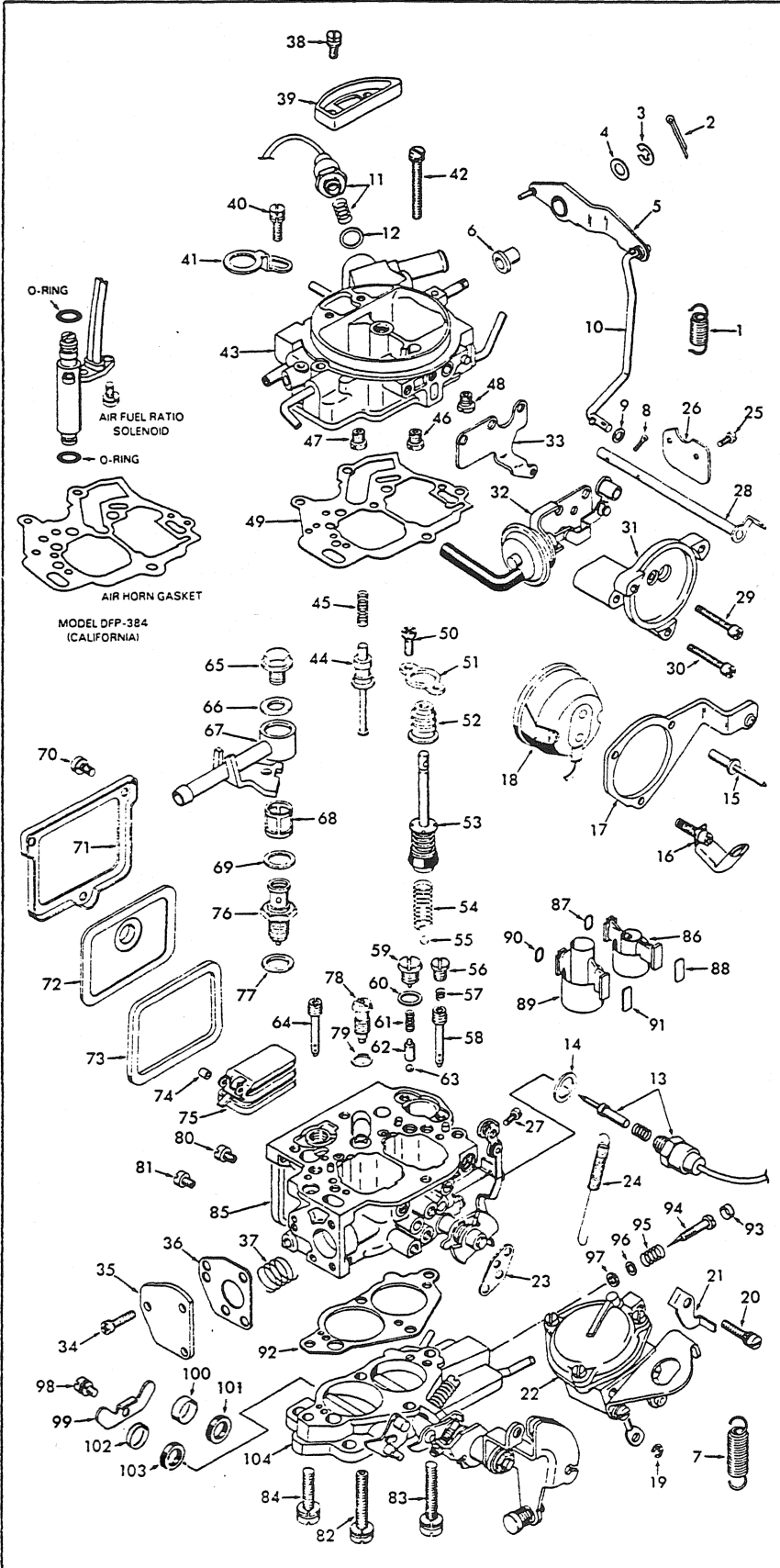

#### DISASSEMBLY

USE THE EXPLODED VIEW AS A GUIDE. THE NUMERICAL SEQUENCE MAY GENERALLY BE FOLLOWED TO DISASSEMBLE UNIT FAR ENOUGH TO PERMIT CLEANING AND INSPECTION. MARK AND REMOVE LEADS FROM HARNESS CONNECTOR FOR EASIER REMOVAL OF SOLENOIDS. CAUTION: ORIGINALLY CHOKE VALVE SCREWS AND SOME OTHERS HAVE LOCK TIGHT APPLIED TO THEM. TAKE EXTRA CARE IN REMOVING THEM. USE PROPER TOOLS. DRILL OR CUT OFF POP RIVET HEADS TO REMOVE CHOKE COVER. REMOVE STAKING FROM AIR HORN FOR EASY REMOVAL OF POWER PISTON ASSEMBLY. NOTE SIZES OF ALL JETS AND THEIR LOCATION FOR PROPER ASSEMBLY. RECORD SIZES BELOW. CAREFULLY DRILL HOLE IN PLUG COVERING IDLE ADJUSTING NEEDLE. USING A PULLER REMOVE PLUG BEFORE REMOVING IDLE ADJUSTING NEEDLE. TURN IN COUNTING THE NUMBER OF TURNS IT TAKES TO LIGHTLY SEAT THE NEEDLE RECORD FOR REASSEMBLY.

NOTE: IF VENTURIS ARE REMOVED TO REPLACE O-RING SEALS, LIGHTLY TAP VENTURI FROM THE BOTTOM SIDE UNTIL IT IS FREE. (REMOVE STAKING ON O-RING SIDE OF VENTURI IF NECESSARY.) INSTALL NEW O-RING AND VENTURI FIRMLY IN PLACE. THEN TAP IN SPRING RETAINER. BE SURE VENTURI IS FIRMLY IN PLACE. LIGHTLY RESTAKE VENTURI ON O-RING SIDE.

CAUTION: DO NOT TURN THE SCREW LIKE PLUGS LOCATED IN THROTTLE BODY HOUSING. (PRIMARY SIDE).

#### NOMENCLATURE

REF. NO.	REF. NO.
1. SPRING - PUMP LEVER RETURN	50. SCREW & LOCKWASHER (2) - PUMP BOOT PLATE
2. COTTER PIN - PUMP LEVER	51. PLATE - BOOT
3. E-CLIP - PUMP LEVER	52. BOOT - PUMP
4. WASHER - PUMP LEVER	53. PUMP ASSEMBLY
5. LEVER - PUMP	54. SPRING - PUMP RETURN
6. BRUSHING - PUMP LEVER	55. BALL - PUMP INTAKE CHECK
7. SPRING - THROTTLE RETURN	56. PLUG - PRI. SLOW JET
8. COTTER PIN - PUMP ROD (LOWER)	57. SPRING - PRI. SLOW JET
9. WASHER (2) - PUMP ROD	58. JET - PRI. SLOW
10. ROD - PUMP	59. PLUG - PUMP CHECK
11. SOLENOID ASSY. - BOWL VENT (SINGLE LEAD)	60. GASKET - PLUG
12. GASKET - SOLENOID	61. SPRING - PUMP BALL WEIGHT
13. SOLENOID ASSY. - IDLE SHUT OFF (TWOLEAD)	62. WEIGHT - PUMP BALL
14. GASKET - SOLENOID	63. BALL - PUMP DISC. CHECK
15. POP RIVET (2) - CHOKE RETAINER	64. JET - SECONDARY SLOW
16. SCREW TO LOCKWASHER - CHOKE RETAINER	65. SCREW - FILTER SET
17. RETAINER - CHOKE COVER	66. GASKET - SCREW
18. CHOKE COVER ASSY. - (ELECTRIC)	67. NIPPLE - FUEL
19. E-CLIP - SEC. DIAPHRAGM STEM	68. SCREEN - FUEL FILTER
20. SCREW & LOCKWASHER (3) - SEC. DIAPHRAGM ASSY.	69. GASKET - NIPPLE
21. STOP PLATE - FAST IDLE CAM	70. SCREW (3) - RETAINER
22. SECONDARY DIAPHRAGM ASSY.	71. RETAINER - WINDOW
23. GASKET - SEC. DIAPHRAGM ASSY.	72. WINDOW - FUEL BOWL
24. SPRING - SEC. THROTTLE RETURN	73. GASKET - WINDOW
25. SCREW (2) - CHOKE VALVE	74. SLEEVE - FLOAT RETAINER
26. VALVE - CHOKE	75. FLOAT ASSEMBLY
27. SCREW & LOCKWASHER - FAST IDLE LINK LEVER	76. NEEDLE & SEAT ASSEMBLY
28. CHOKE SHAFT	77. GASKET (SERVICE) - NEEDLE SEAT
29. SCREW & LOCKWASHER - CHOKE HOUSING	78. POWERVERVALVE ASSEMBLY
30. SCREW & LOCKWASHER - CHOKE HOUSING	79. GASKET - POWER VALVE
31. CHOKE HOUSING	80. JET - PRI. MAIN
32. CHOKE PULL-OFF & BRACKET ASSY.	81. JET - SEC. MAIN
33. BRACKET	82. SCREW & LOCKWASHER (1) - THROTTLE BODY (HOLLOW)
34. SCREW & LOCKWASHER (3) - PLATE 35. PLATE	83. SCREW & LOCKWASHER (1) - THROTTLE BODY (LONG)
36. GASKET - PLATE	84. SCREW & LOCKWASHER (2) - THROTTLE BODY
37. SPRING - PLUG	85. BOWL ASSEMBLY
38. SCREW & LOCKWASHER (2) - VENT COVER	86. VENTURI PRIMARY
39. AIR VENT COVER	87. O-RING - PRI. VENTURI SEAL
40. SCREW & WASHER - LOCK LEVER	88. RETAINER - PRI. VENTURI
41. LOCK LEVER - FILTER SET SCREW	89. VENTURI - SECONDARY
42. SCREW & LOCKWASHER (4) - AIR HORN (DIFF. LENGTHS)	90. O-RING - SEC. VENTURI SEAL
43. AIR HORN ASSY.	91. RETAINER - SEC. VENTURI
44. PISTON - POWER VALVE	92. GASKET - THROTTLE BODY
45. SPRING - POWER PISTON	93. PLUG - IDLE NEEDLE
46. JET - PRI. MAIN AIR BLEED	94. NEEDLE - IDLE ADJUSTING
47. JET - SEC. MAIN AIR BLEED	95. SPRING - IDLE NEEDLE
48. JET - PRI. SLOW AIR BLEED	96. WASHER - NEEDLE SEAL
49. GASKET - AIR HORN	97. SEAL - IDLE ADJUSTING NEEDLE
	98. SCREW & LOCKWASHER - RETAINER
	99. RETAINER - THROTTLE SHAFT SEALS
	100. CUP - PRI. SHAFT SEAL
	101. SEAL - PRI. SHAFT
	102. CUP - SEC. SHAFT SEAL
	103. SEAL - SEC. SHAFT
	104. THROTTLE BODY ASSEMBLY

#### CLEANING

CLEANING MUST BE DONE WITH CARBURETOR DISASSEMBLED. SOAK PARTS (SEE CAUTION BELOW) LONG ENOUGH TO SOFTEN AND REMOVE ALL FOREIGN MATERIAL. USE A CARBURETOR CLEANER SOLVENT. MAKE CERTAIN THE THROTTLE BODY IS FREE OF ALL CARBON DEPOSITS. WASH OFF IN SUITABLE SOLVENT. BLOW OUT ALL PASSAGES IN CASTINGS WITH COMPRESSED AIR AND CHECK CAREFULLY TO INSURE THOROUGH CLEANING OF OBSCURE AREAS. CAUTION: DO NOT EXTEND CLEANING PERIOD OF PARTS WITH ATTACHED PLASTIC COMPONENTS. DO NOT SOAK AIR HORN WITH RUBBER VENT VALVE OR PARTS SUCH AS (11), (13), (18), (22), (32), (43), (68), (72), (75) IN ANY TYPE OF CLEANING SOLVENTS.

#### REASSEMBLY

REASSEMBLE IN REVERSE ORDER OF DISASSEMBLY. NOTE SPECIAL INSTRUCTIONS AND ADJUSTMENTS.

#### SPECIAL INSTRUCTIONS

IDLE ADJUSTING NEEDLE - TURN NEEDLE IN UNTIL LIGHTLY SEATED, THEN BACK OUT NUMBER OF TURNS RECORDED ON DISASSEMBLY.

PUMP RETURN SPRING - INSTALL WITH CROSS WIRE TO THE BOTTOM OF PUMPS CYLINDER AND IN SLOT.

POWER PISTON - AFTER INSTALLING LIGHTLY RESTAKE CASTING AROUND WASHER.

# ADJUSTMENTS

