

INSTRUCTION SHEET
MIXTURE CONTROL ADJUSTMENTS
ROCHESTER CARBS, MODELS - E2MC, E2ME, E4MC, E4ME
(COMPUTER COMMAND CONTROLLED)

FOLLOW NUMERICAL SEQUENCE IN MAKING ADJUSTMENTS. IF CARBURETOR HAS BEEN DISASSEMBLED FOR CLEANING MAKE ADJUSTMENTS AS CARBURETOR IS REASSEMBLED.

OR

REMOVE AIRHORN (BOWL COVER), SOLENOID PLUNGER, COVER GASKET, PLASTIC FILLER BLOCK AND METERING RODS.

NOTE: REMOVE COVER FROM IDLE AIR BLEED VALVE. REMOVE IDLE AIR BLEED VALVE FROM BOWL COVER. NEXT REMOVE RICH MIXTURE STOP SCREW FROM BOWL COVER (SCREW WITH LARGE FLAT SURFACE). USING A PUNCH KNOCK OUT SEAL PLUG. REPLACE SCREW (AND SPRING IF USED) UNTIL LIGHTLY SEATED.

1. LEAN MIXTURE SCREW ADJUSTMENT

- A. INSTALL GAUGE ON THROTTLE SIDE METERING JET.
- B. INSTALL SOLENOID PLUNGER.
- C. PRESS DOWN ON CENTER OF SOLENOID PLUNGER AND ADJUST LEAN MIXTURE SCREW (WITH ADJUSTING WRENCH) SLOWLY UNTIL PLUNGER IS CONTACTING STOP AND JUST TOUCHING GAUGE. AFTER CONTACT 1/4 TURNS EITHER WAY WILL VERIFY CORRECT SETTING.
- D. REASSEMBLE CARBURETOR.

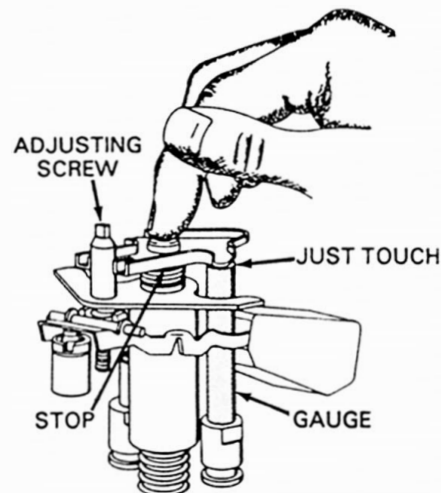

2. RICH STOP SCREW ADJUSTMENT (PLUNGER TRAVEL)

- A. INSERT PLASTIC GAUGE INTO "D" SHAPED HOLE IN AIR HORN. WITH SCALE FACING TOWARDS FUEL INLET, TAKE A MEASUREMENT AT THIS POINT THEN PRESS DOWN ON SCALE CAREFULLY AND TAKE A MEASUREMENT. ADJUST PLUNGER TRAVEL TO 4/32". TO ADJUST TURN RICH STOP SCREW WITH ADJUSTING WRENCH.
- B. RE-INSTALL PLUG IN ACCESS HOLE

NOTE: CARBURETORS WITH RICH LIMITER STOP BRACKET DO NOT HAVE A RICH STOP ADJUSTMENT AS BEFORE.

TO ADJUST

1. LEAN MIXTURE ADJUSTMENT IS MADE AS BEFORE.
2. AFTER LEAN MIXTURE ADJUSTMENT NOTE POSITION OF TOOL HANDLE AND RECORD NUMBER OF TURNS IT TAKES TO TURN ADJUSTING SCREW CLOCKWISE UNTIL SOLENOID BOTTOMS OUT AGAINST FLOAT BOWL.
3. REMOVE GAUGE AND REASSEMBLE ALL NECESSARY PARTS.
4. TURN SOLENOID ADJUSTING SCREW CLOCKWISE UNTIL SOLENOID BOTTOMS OUT AGAINST FLOAT BOWL, THEN TURN COUNTERCLOCKWISE THE NUMBER OF TURNS RECORDED IN STEP 2.

3. IDLE AIR BLEED VALVE. PRE-ADJUSTMENT (BENCH ADJ.)

- A. IDLE AIR BLEED VALVE INSTALLED IN AIR HORN.
- B. INSERT PLASTIC GAUGE INTO "D" SHAPED HOLE IN AIRHORN WITH SHORT LEG OF GAUGE POSITIONED OVER IDLE AIR BLEED VALVE. PRESS DOWN LIGHTLY ON GAUGE UNTIL SOLENOID PLUNGER BOTTOMS ON STOP. (NOT THE GAUGE ON IDLE AIR BLEED VALVE). ADJUST IDLE AIR BLEED VALVE UNTIL IT JUST TOUCHES GAUGE.

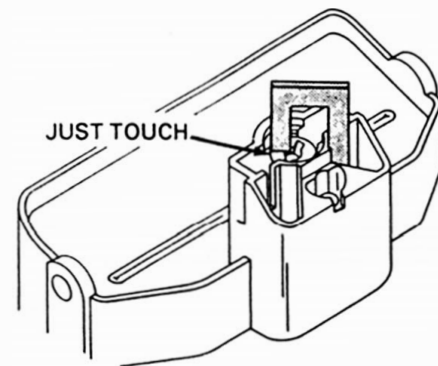
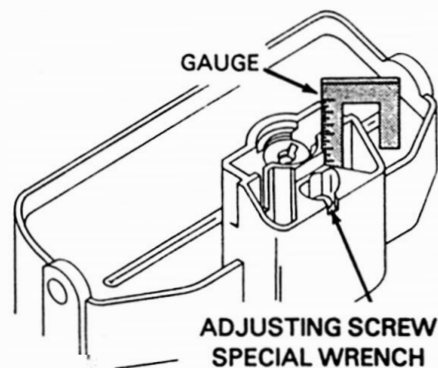

FOLLOW MANUFACTURERS PROCEDURE FOR ON CAR FINAL ADJUSTMENTS.

GAUGE KIT AVAILABLE AT THE DEALER