

SOLEX 32 PBI 32 PBI-C 32 PBICT 34 PBIC 40 PBIC 40 PICB CARBURETORS

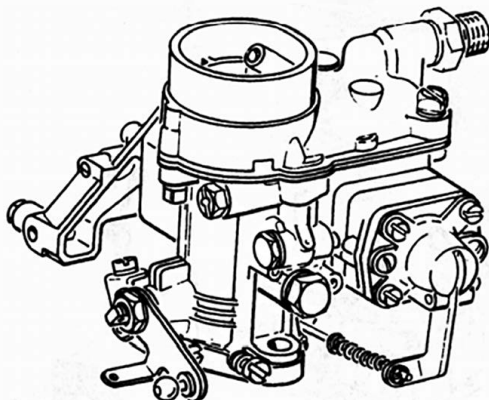

I. DISASSEMBLY.

The exploded view illustration on reverse side of sheet shows all parts of the carburetor "exploded" out of their respective assembled positions for reference during overhaul operations. The carburetor should be disassembled only to the extent necessary to permit a thorough cleaning, inspection of parts and installation of parts in Tune-Up Kit.

II. CLEANING.

Soak parts long enough to soften and remove all foreign material. Use a regular carburetor cleaning solvent; lacquer thinner; or denatured alcohol. Use a small brush to aid cleaning, if necessary. Make certain the throttle body is free of all hard carbon deposits. Blow out all passages in castings with compressed air, and check carefully to insure thorough cleaning of obscure areas. Do not soak rubber or leather parts in solvent.

III. REASSEMBLY.

Reassemble the carburetor with care, using new gaskets and other parts in kit to replace like parts in the unit. Refer to the drawing, on opposite side of sheet for location of parts. Exercise care to avoid damage to parts. As each component is assembled check it with respect to the function it is to perform in order to avoid possible "binds" and incorrect hook-ups.

IV. ADJUSTMENTS.

Install carburetor and warm up engine. Adjust idle with the throttle stop screw and idle mixture needle until engine runs smoothly at proper speed. (See car manufacturer's recommendations for correct idle speed.) Do not attempt to change the automatic choke (autostarter 32PBICT) setting.

GENERAL EXPLODED VIEW
THE GENERAL DESIGN AND PARTS SHOWN WILL VARY TO
INDIVIDUAL UNITS COVERED ON THIS INSTRUCTION SHEET

SOLEX 32 PBI and 32 PBI-C CARBURETORS

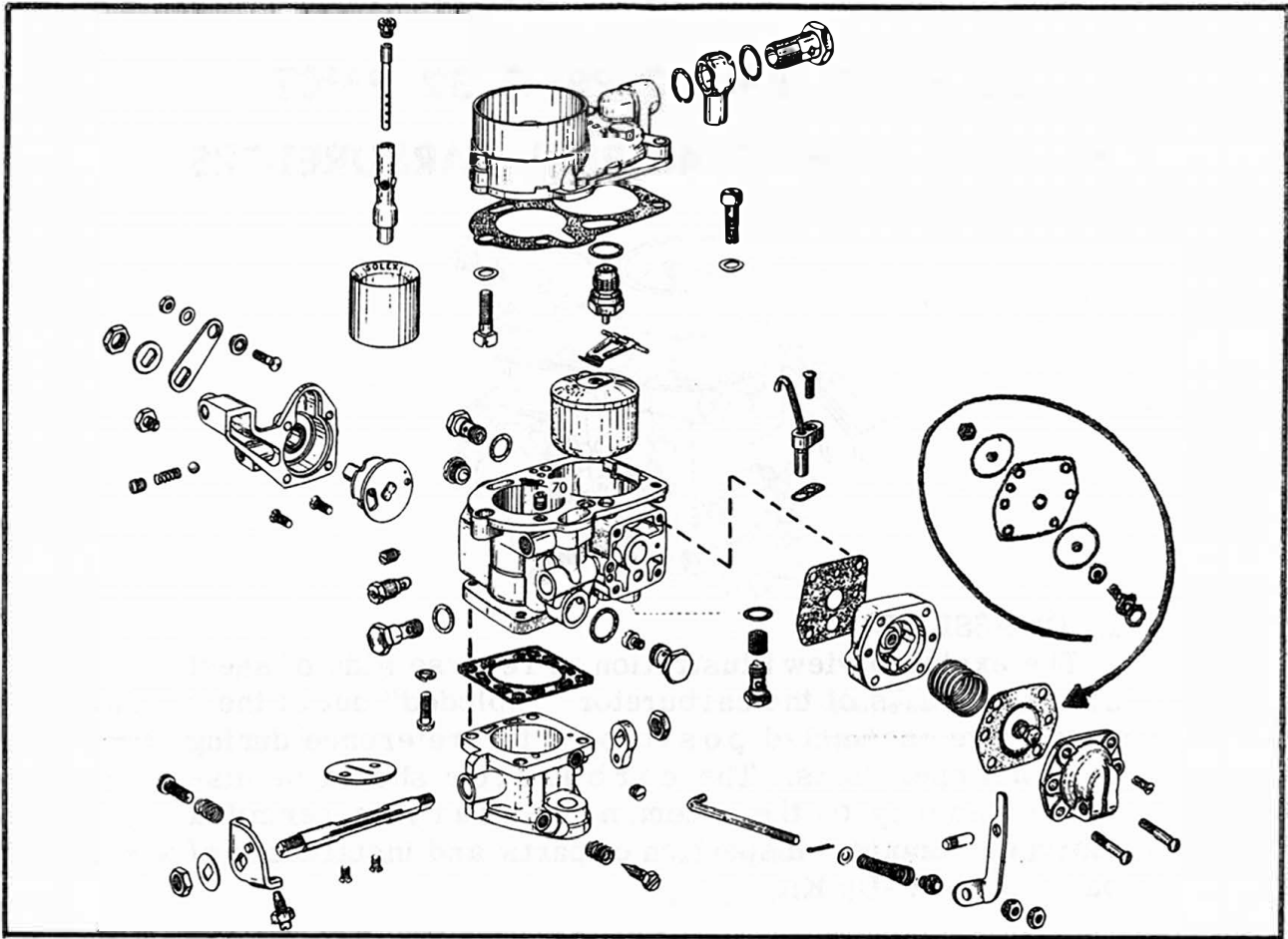

SOLEX 32 PBIC 32 PBICT 34 PBIC 40 PBIC and 40 PICB CARBURETORS

