

INSTRUCTION SHEET

SOLEX CARBURETOR — MODELS 34 PDSIT - 2, - 3

JULY 1972 TO 1974 - TYPE 2

50-565

GENERAL EXPLODED VIEW

THE GENERAL DESIGN AND PARTS SHOWN WILL VARY TO INDIVIDUAL UNITS COVERED ON THIS INSTRUCTION SHEET.

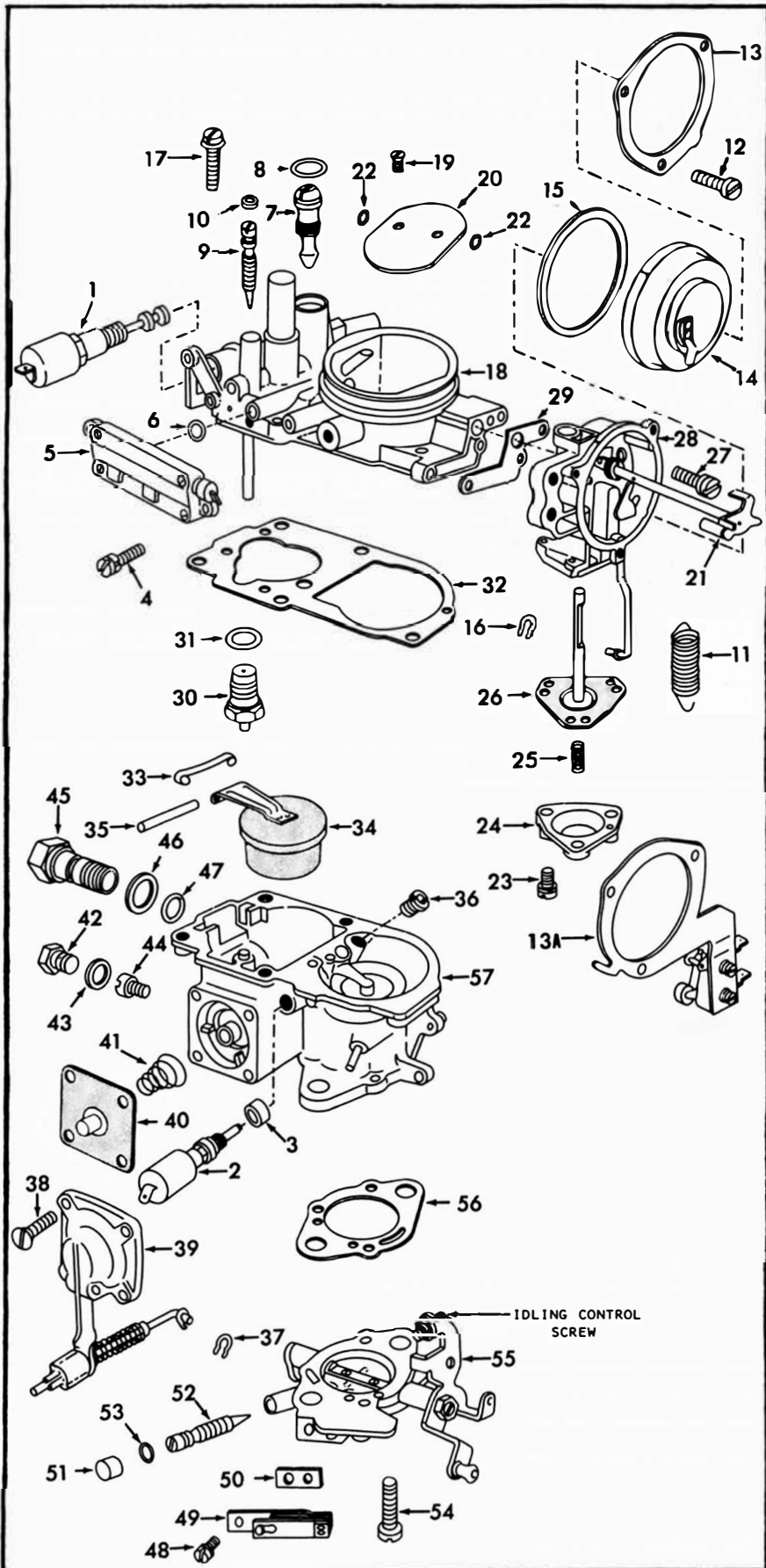

REMOVING

REMOVE AIR CLEANER. DISCONNECT FUEL HOSE, CABLE FOR AUTOMATIC CHOKE, AND IDLE CUT-OFF VALVE, AND IF REBUILDING THE LEFT CARBURETOR, REMOVE VACUUM HOSE FOR DISTRIBUTOR. REMOVE CARBURETOR LINKAGE RETURN SPRING AND CONNECTING ROD. REMOVE TWO NUTS FROM STUDS ON CARBURETOR FLANGE AND TAKE OFF CARBURETOR.

DISASSEMBLY

USE EXPLODED VIEW AS A GUIDE. THE NUMERICAL SEQUENCE MAY GENERALLY BE FOLLOWED TO DISASSEMBLE UNIT FAR ENOUGH TO PERMIT CLEANING AND INSPECTION. CAUTION: BRASS TUBE TYPE JETS ARE NOT REMOVABLE. BEFORE REMOVING CHOKE PLATE SCREWS (19) FILE OFF PEENED END FOR EASY REMOVAL.

NOMENCLATURE

REF. NO.	REF. NO.
1. VALVE - BYPASS AIR CUT OFF VALVE - IDLE CUT-OFF	29. GASKET - CHOKE HOUSING
2. VALVE - IDLE CUT-OFF	30. NEEDLE & SEAT ASSY.
3. SEALING WASHER - IDLE CUT-OFF VALVE	31. GASKET - NEEDLE SEAT
4. SCREW & LOCKWASHER (2) - VALVE	32. GASKET - UPPER BODY
5. VALVE - THERMO CUT-OFF	33. SEAT SPRING - FLOAT PIN
6. O-RING-THERMO CUT-OFF VALVE	34. FLOAT
7. SCREW - BYPASS AIR	35. PIN-FLOAT LEVER
8. O-RING-BYPASS AIR SCREW	36. JET - AIR CORRECTION
9. SCREW - CONTROL	37. LOCKRING - CONNECTION ROD
10. O-RING-CONTROL SCREW	38. SCREW (4) - COVER WITH LEVER AND ROD
11. SPRING-RETURN	39. COVER - WITH LEVER AND CONNECTION ROD
12. SCREW(3) - RETAINING RING	40. DIAPHRAGM - PUMP
13. RETAINING RING-COVER	41. SPRING-DIAPHRAGM
13A. RETAINING RING & MICRO SWITCH -(RIGHT SIDE CARB' A/T.)	42. PLUG - MAIN JET
14. COVER - WITH SPRING & HEATER ELEMENT	43. GASKET - PLUG
15. GASKET - COVER	44. JET - MAIN
16. CLIP-CONNECTOR ROD	45. PLUG-FUEL BOWL (SOME LATE MODELS)
17. SCREW & LOCKWASHER (5) - UPPER BODY	46. GASKET - PLUG
18. BODY ASSY. - UPPER	47. O-RING-PLUG
19. SCREW (2) - CHOKE PLATE	48. SCREW & LOCKWASHER - HOT IDLE VALVE
20. PLATE - CHOKE	49. VALVE - HOT IDLE
21. SHAFT - CHOKE PLATE	50. GASKET - HOT IDLE VALVE
22. SPACEWASHER (2) - CHOKE PLATE	51. SEAL PLUG - VOLUME CONTROL SCREW
23. SCREW & LOCKWASHER (3) - COVER	52. SCREW - VOLUME CONTROL
24. COVER - VACUUM DIAPHRAGM	53. O-RING VOLUME CONTROL SCREW
25. SPRING - VACUUM DIAPHRAGM	54. SCREW(2) - THROTTLE HOUSING
26. VACUUM DIAPHRAGM - CHOKE	55. THROTTLE HOUSING ASSY.
27. SCREW & LOCKWASHER (2) - CHOKE HOUSING	56. GASKET - MAIN BODY TO THROTTLE HOUSING
28. HOUSING ASSY. - CHOKE	57. MAIN BODY ASSY.

CLEANING

CLEANING MUST BE DONE WITH CARBURETOR DISASSEMBLED. SOAK PARTS LONG ENOUGH TO SOFTEN AND REMOVE ALL FOREIGN MATERIAL. USE A CARBURETOR CLEANING SOLVENT. MAKE CERTAIN THE THROTTLE BODY IS FREE OF ALL HARD CARBON DEPOSITS. WASH OFF IN SUITABLE SOLVENT. BLOW OUT ALL PASSAGES IN CASTINGS WITH COMPRESSED AIR AND CHECK CAREFULLY TO INSURE THOROUGH CLEANING OF OBSCURE AREAS. CAUTION: DO NOT SOAK SOLENOIDS, SWITCHES, FLOAT, OR RUBBER PARTS IN SOLVENTS.

REASSEMBLY

REASSEMBLE IN REVERSE ORDER OF DISASSEMBLY, GIVING SPECIAL ATTENTION TO THE FOLLOWING SPECIAL INSTRUCTIONS.

SPECIAL INSTRUCTIONS

MAKE SURE ALL JET ORIFICES ARE CLEAN AND OPEN. CLEAN WITH COMPRESSED AIR. DO NOT USE WIRES TO CHECK FOR CLOGGED ORIFICES.

WHEN INSTALLING THE PUMP DIAPHRAGM AND SPRING (41) MAKE SURE THE LARGER END OF SPRING IS PROPERLY SEATED IN THE CARBURETOR BODY CAVITY. BE SURE TO INSTALL THE DIAPHRAGM (40) WITH PLUNGER TOWARD PUMP COVER (39).

CHECK FOR A WORN SPOT (DEPRESSION) ON THE FLOAT LEVER WHERE IT MAKES CONTACT WITH THE FUEL INLET NEEDLE VALVE. REPLACE FLOAT ASSEMBLY IF NECESSARY. FLOAT ASSEMBLY MAY BE PURCHASED AT LOCAL VW DEALER, P/N 311-129-391A ROUND SHAPED FLOAT (34).

CHECK THE THERMOSTATIC SPRING IN HOUSING (ITEM #14) FOR DAMAGE IF IT IS DISTORTED OR "KINKED", REPLACE THE ASSEMBLY. ALSO, MAKE SURE THE ELECTRICAL HEATING ELEMENT IS NOT BROKEN. THIS CAN BE CHECKED WITH AN OHMMETER OR CONNECTED TO A CORRECT VOLTAGE BATTERY FOR A FEW MINUTES TO SEE IF IT WARMS UP. (BE SURE TO GROUND THE INSIDE METAL PART OF THE HOUSING IN ORDER TO COMPLETE THE CIRCUIT.) WHEN INSTALLING ASSEMBLY WITH SPRING AND HEATER ELEMENT, CAREFULLY ROTATE ASSEMBLY COUNTERCLOCKWISE, BEING SURE THE HOOK ON COIL END ENGAGES WITH THE LEVER ON CHOKE SHAFT. CONTINUE ROTATING APPROXIMATELY 1/8 TURN MORE UNTIL INDEX MARKS ALIGN. THEN TIGHTEN SCREWS SECURELY.

INSTALLING

INSTALL IN REVERSE ORDER OF REMOVING.

SYNCHRONIZATION OF CARBURETORS

WARM UP ENGINE. DISCONNECT OPERATING ROD FOR THROTTLE VALVE SHAFT ON RIGHT CARBURETOR. PULL HOSE OFF RETARD CHAMBER OF VACUUM UNIT ON DISTRIBUTOR. PULL LEFT HOSE OFF AIR PUMP AND SEAL THE HOSE. DISCONNECT WIRE FROM TERMINAL OF CUT-OFF VALVE (1) ON CENTRAL IDLING SYSTEM. TURN VOLUME CONTROL SCREW (52) ON BOTH CARBURETORS IN AS FAR AS THEY WILL GO. DO NOT USE FORCE. THEN TURN OUT 2 1/2 TURNS. START ENGINE AND SET IDLING SPEED TO 500-700 RPM AND CO VALUE TO 3-5% BY TURNING BOTH VOLUME CONTROL SCREWS (52) UNIFORMLY. DISCONNECT IDLING CUT-OFF VALVE WIRE (2) ON ONE CARBURETOR AND NOTE THE DECREASE IN SPEED. THE DECREASE IN SPEED MUST BE THE SAME WHEN THIS PROCEDURE IS REPEATED ON THE OTHER CARBURETOR. OTHERWISE, THE MIXTURE MUST BE REGULATED BY ADJUSTING THE VOLUME CONTROL SCREWS (52). CONNECT OPERATING ROD FOR THROTTLE VALVE SHAFT, BEING CAREFUL NOT TO CHANGE THE POSITION OF THE THROTTLE VALVE. CONNECT WIRE TO TERMINAL OF CUT-OFF VALVE (1) ON CENTRAL IDLING SYSTEM AND INSTALL HOSES ON RETARD UNIT AND AIR PUMP. INCREASE SPEED BRIEFLY AND THEN SET IDLING WITH THE IDLING CONTROL SCREWS TO APPROXIMATELY 950 RPM.

IDLING ADJUSTMENT

CONNECT TACHOMETER. START ENGINE, AUTOMATIC CHOKE FULLY OPEN, SET IDLE SPEED BY TURNING THE BYPASS AIR SCREW (7) TO SPEED RANGE GIVEN IN THE FOLLOWING TABLE:

MANUAL TRANSMISSION	850- 900 RPM
AUTOMATIC TRANSMISSION	900-1,000 RPM

TURN CONTROL SCREW (9) OUT UNTIL ENGINE SPEED INCREASES. THEN TURN IN SLOWLY UNTIL ENGINE SPEED STARTS TO DROP; THEN TURN IT TO THE LEFT 1/2 TO 1 TURN UNTIL THE ENGINE RUNS SMOOTHLY. STARTING AT THIS POINT, TURN THE CONTROL SCREW (9) IN AGAIN UNTIL THE ENGINE SPEED DROPS APPROXIMATELY 20-30 RPM. IF BY WEAKENING THE MIXTURE IN THIS MANNER THE ENGINE NO LONGER RUNS EVENLY, THE SCREW MUST BE TURNED OUT AGAIN VERY SLIGHTLY UNTIL THE ENGINE CONTINUES TO RUN SMOOTHLY. CHECK AND MAKE SURE THAT THE ENGINE SPEED CORRESPONDS TO THE SPEED RANGE GIVEN IN THE TABLE.