

INSTRUCTION SHEET

OFF VEHICLE CARBURETOR SERVICE

ROCHESTER — MODEL 2G, 2GC

GENERAL EXPLODED VIEW

THE GENERAL DESIGN AND PARTS SHOWN WILL VARY TO
INDIVIDUAL UNITS COVERED ON THIS INSTRUCTION SHEET

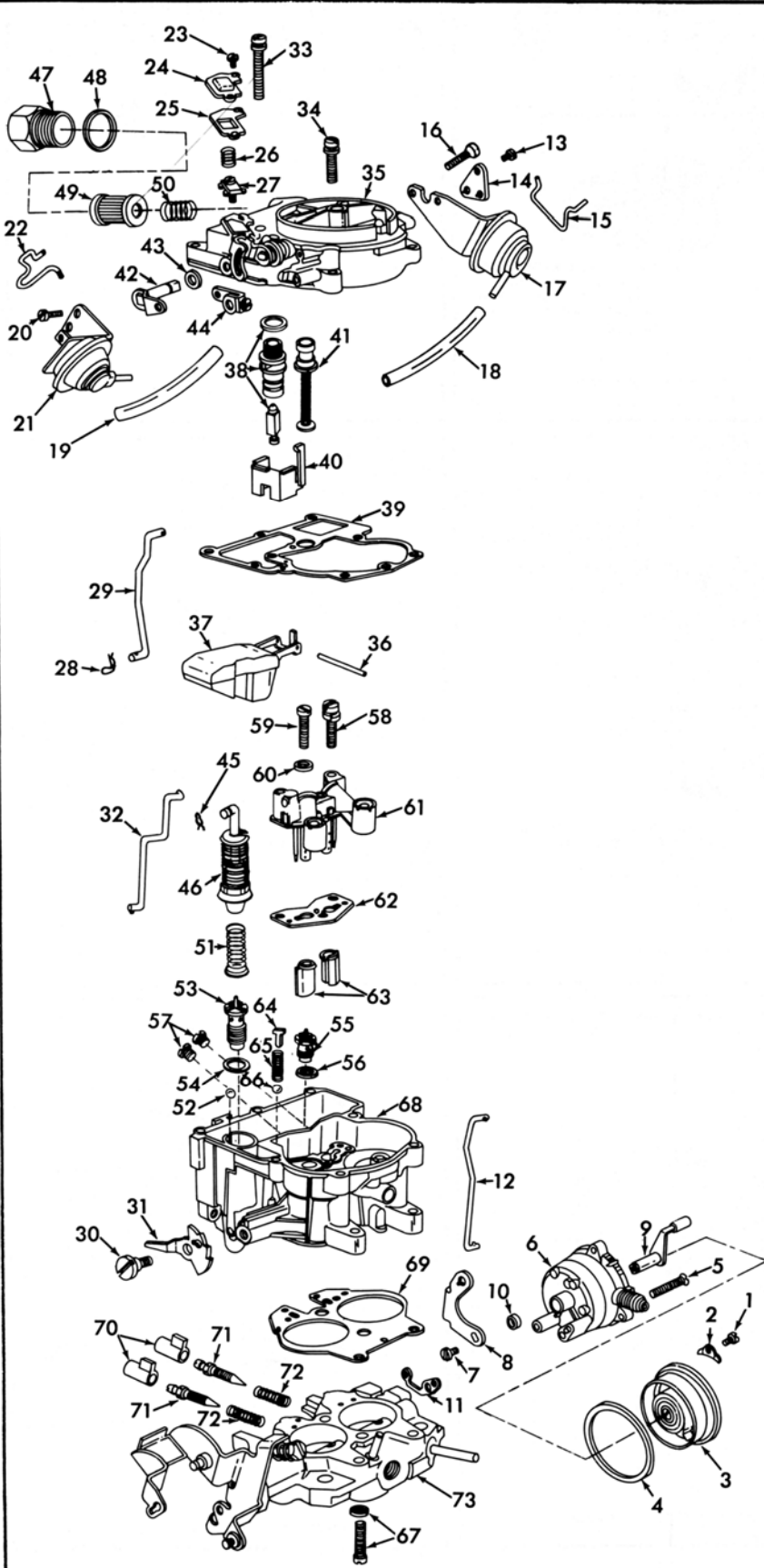

DISASSEMBLY

USE EXPLODED VIEW AS A GUIDE. THE NUMERICAL SEQUENCE MAY GENERALLY BE FOLLOWED TO DISASSEMBLE UNIT FAR ENOUGH TO PERMIT CLEANING AND INSPECTION. NOTE: TO REMOVE PUMP ASSY. (46), TWIST UPSET END WITH SMALL PLIERS UNTIL IT BREAKS OFF. SERVICE PUMP WILL HAVE A RETAINING CLIP GROOVE. REMOVE STAKING FROM BOWL COVER FOR EASY REMOVAL OF POWER PISTON ASSEMBLY (41). IDLE LIMITER CAPS (70) CAN EASILY BE REMOVED BY BREAKING OFF WITH A PAIR OF PLIERS. NO REPLACEMENT CAPS ARE NECESSARY AS A BARE MIXTURE SCREW IS SUFFICIENT TO INDICATE THAT THE MIXTURE HAS BEEN READJUSTED. BEFORE REMOVING IDLE ADJUSTING NEEDLES (71), TURN IN TO COUNT THE NUMBER OF TURNS NEEDLES ARE OUT FROM A SEATED POSITION. SOME MODELS IN 1980-81 WILL HAVE A PUMP LEVER SHAFT SEAL. USE A SMALL SCREW DRIVER TO PRY OUT THE OLD SEAL. AFTER CLEANING INSTALL NEW SEAL WITH THE LIP OF SEAL FACING OUTWARD.

NOMENCLATURE

REF. NO.	REF. NO.
1. SCREW (3)-CHOKE COVER RETAINER	35. BOWL COVER ASSY.
2. RETAINER (3)-CHOKE COVER	36. PIN - FLOAT HINGE
3. CHOKE COVER & SPRING ASSY.	37. FLOAT & LEVER ASSY.
4. GASKET - CHOKE COVER	38. NEEDLE, SEAT & GASKET ASSY.
5. SCREW (2)-CHOKE HOUSING	39. GASKET-BOWL COVER
6. CHOKE HOUSING ASSY.	40. BAFFLE - FUEL
7. SCREW - LEVER	41. POWER PISTON ASSY.
8. LEVER-INTERMEDIATE CHOKE	42. PUMP LEVER SHAFT
9. SHAFT ASSY.-INTERMEDIATE CHOKE	43. WASHER-PUMP SHAFT (NYLON)
10. SEAL-INTERMEDIATE CHOKE SHAFT	44. LEVER - INNER PUMP
11. GASKET - CHOKE HOUSING	45. RETAINER (SERVICE ITEM)
12. ROD-INTERMEDIATE CHOKE	46. PUMP ASSY.
13. SCREW-CHOKE SHAFT LEVER	47. FITTING - FUEL INLET
14. LEVER - CHOKE SHAFT	48. GASKET - FITTING
15. LINK-AUX. VACUUM BREAK	49. FILTER - FUEL
16. SCREW (2)-AUX. VACUUM BREAK	50. SPRING - FUEL FILTER
17. AUXILIARY VACUUM BREAK ASSY.	51. SPRING - PUMP RETURN
18. HOSE-AUX. VAC. BREAK	52. BALL-PUMP INTAKE CHECK (ALUM)
19. HOSE-PRI. VAC. BREAK	53. POWER VALVE ASSY.-MECH.
20. SCREW (2)-PRI. VAC. BREAK	54. GASKET - POWER VALVE
21. PRIMARY VACUUM BREAK ASSY.	55. POWER VALVE ASSY.-VAC.
22. LINK-PRI. VAC. BREAK	56. GASKET-POWER VALVE
23. SCREW (2)-VENT COVER	57. JET (2) - MAIN
24. COVER - VENT VALVE	58. SCREW & LOCKWASHER (2)-VENTURI CLUSTER
25. GASKET - VENT COVER	59. SCREW-VENTURI CLUSTER CENTER
26. SPRING - VENT VALVE	60. GASKET - CENTER SCREW
27. VENT VALVE ASSY.	61. VENTURI CLUSTER ASSY.
28. RETAINER - PUMP ROD	62. GASKET-VENTURI CLUSTER
29. ROD - PUMP	63. INSERT (2)-MAIN WELL
30. SCREW - FAST IDLE CAM	64. GUIDE-PUMP DISC. SPRING
31. CAM - FAST IDLE	65. SPRING-PUMP DISC. BALL
32. ROD - CHOKE	66. BALL-PUMP DISC. (STEEL)
33. SCREW & LOCKWASHER (1)-BOWL COVER (LONG)	67. SCREW & LOCKWASHER (3)-THROTTLE BODY
34. SCREW & LOCKWASHER (7)-BOWL COVER	68. BOWL ASSY.
	69. GASKET-THROTTLE BODY
	70. CAP (2)-IDLE LIMITER
	71. NEEDLE (2)-IDLE ADJUSTING
	72. SPRING (2)-IDLE ADJ. NEEDLE
	73. THROTTLE BODY ASSY.

CLEANING

CLEANING MUST BE DONE WITH CARBURETOR DISASSEMBLED. USE A CARBURETOR CLEANING SOLVENT TO SOAK PARTS LONG ENOUGH TO SOFTEN AND REMOVE ALL FOREIGN MATERIAL. MAKE CERTAIN THE THROTTLE BORES ARE FREE OF ALL CARBON AND VARNISH DEPOSITS. RINSE OFF IN SUITABLE SOLVENT. BLOW OUT ALL PASSAGES IN CASTINGS WITH COMPRESSED AIR AND CHECK CAREFULLY TO INSURE THOROUGH CLEANING OF OBSCURE AREAS. CAUTION: DO NOT SOAK FLOAT, DIAPHRAGM UNITS, RUBBER OR PLASTIC PARTS IN SOLVENT. DO NOT SAND, WIRE BRUSH, OR FILE ON TEFLON-COATED PARTS.

REASSEMBLY

REASSEMBLE IN REVERSE ORDER OF DISASSEMBLY. NOTE SPECIAL INSTRUCTIONS AND FOLLOW NUMERICAL OUTLINE IN MAKING ADJUSTMENTS NECESSARY FOR CARBURETOR BEING SERVICED.

SPECIAL INSTRUCTIONS

IDLE ADJUSTING NEEDLES (71) - TURN EACH NEEDLE IN UNTIL LIGHTLY SEATED, THEN BACK OUT NUMBER OF TURNS COUNTED ON DISASSEMBLY.

PUMP RETURN SPRING (51) - INSTALL WITH LARGE END TO BOTTOM OF PUMP WELL.

POWER PISTON ASSY. (41) - LIGHTLY STAKE CASTING AROUND WASHER.

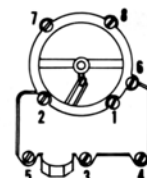

AIR HORN TIGHTENING SEQUENCE

INTERMEDIATE CHOKE SHAFT SEAL (10) - INSTALL SEAL WITH LIP FACING OUT.

CHOKE COVER GASKET (4) - DO NOT USE WITH ELECTRIC CHOKE COVER, IT MUST BE GROUNDED.

ADJUSTMENTS

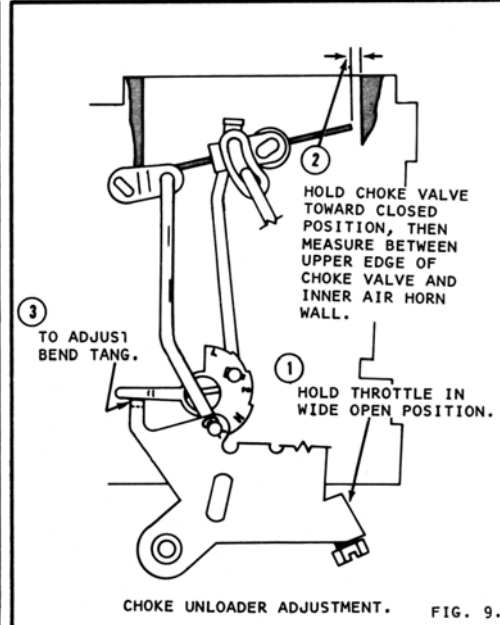
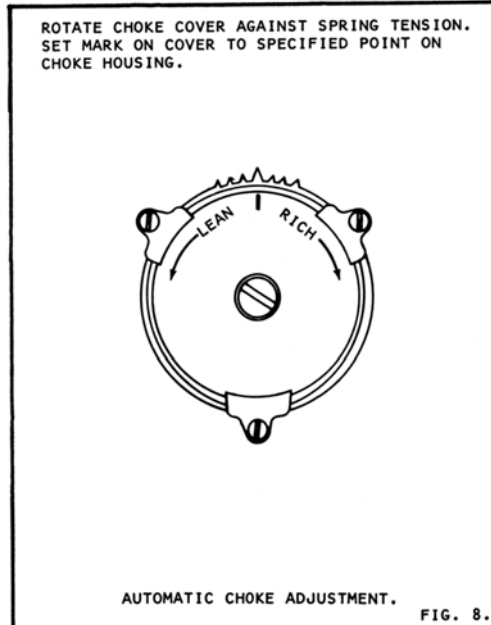
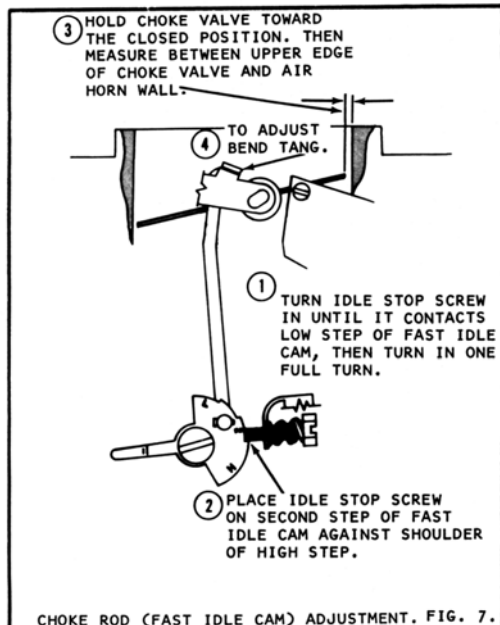
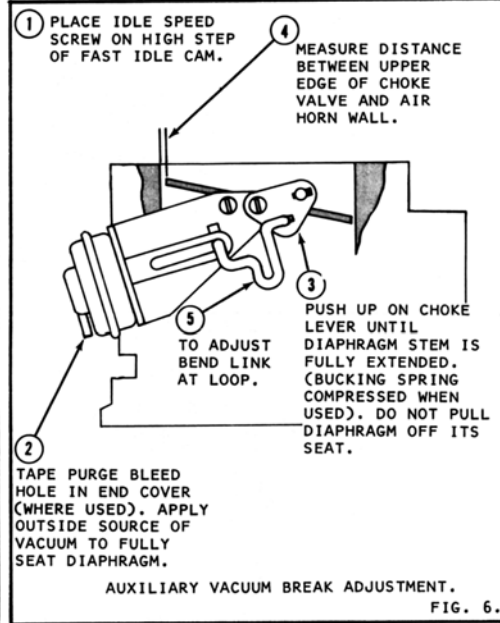
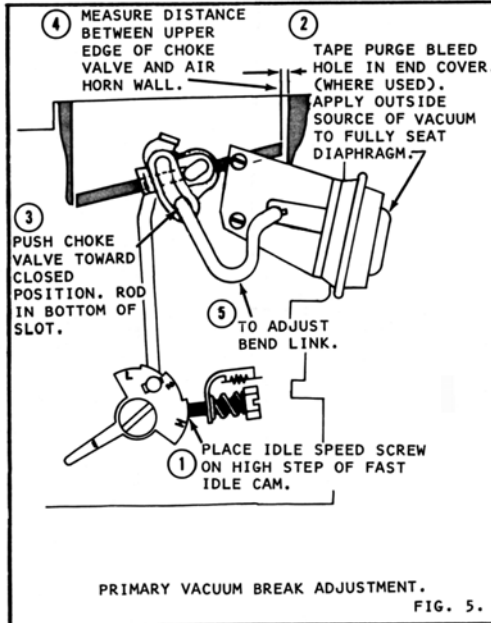
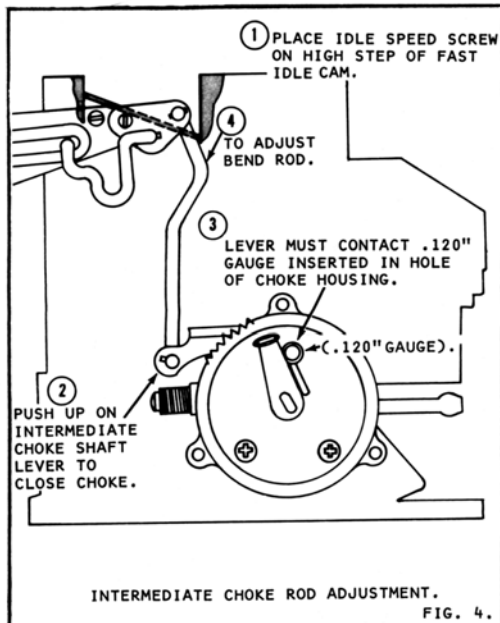
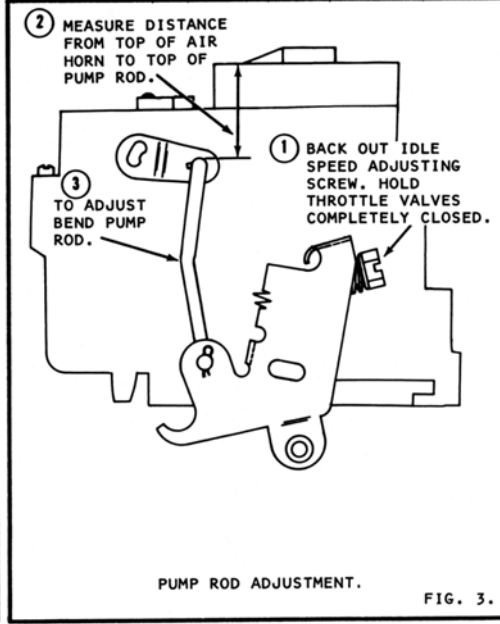
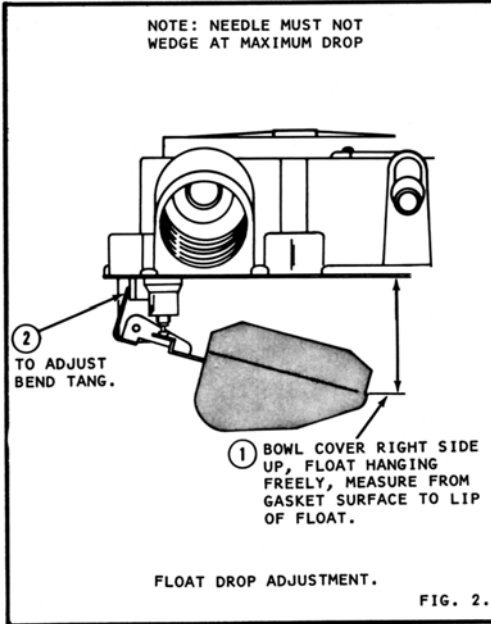
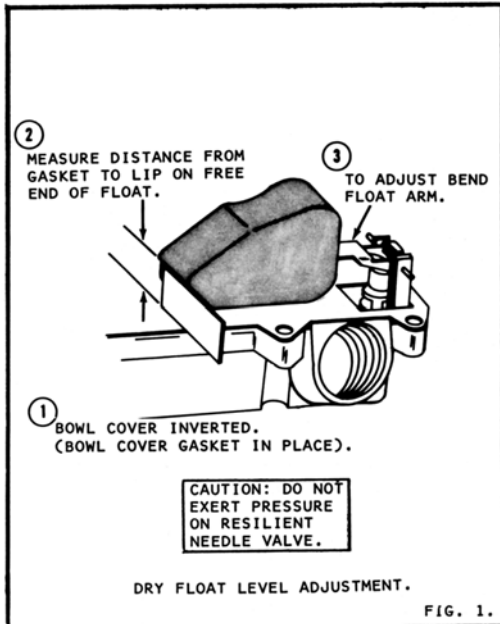

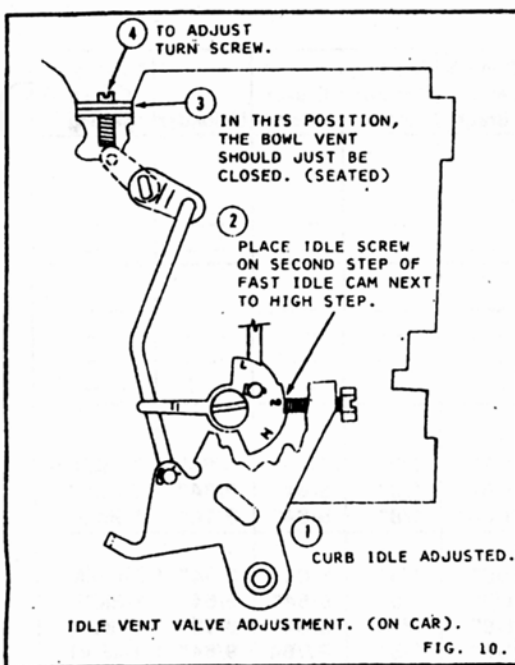

ADJUSTMENT DATA TABLE ROCHESTER CARBURETOR MODEL 2GC

Year	Application		Float Level	Float Drop	Pump Rod Setting	Primary Vacuum Break	Auxiliary Vacuum Break	Choke Rod	Unloader	Automatic Choke Setting	
BUICK											
1975	231" Eng. V6 Carb #7045145	A/T	7/16"	1 9/32"	1 19/32"	1/8"	1/8"	5/64"	9/64"	1-RICH	
		M/T	7/16"	1 9/32"	1 19/32"	3/16"	1/8"	5/64"	9/64"	1-LEAN	
	231" Eng. V6 350" Eng. V8	Calif.	M/T	7/16"	1 9/32"	1 19/32"	1/8"	1/8"	5/64"	9/64"	1-LEAN
		A/T	7/16"	1 9/32"	1 19/32"	1/8"	1/8"	5/64"	9/64"	1-LEAN	
		A/T	15/32"	1 9/32"	1 19/32"	9/64"	1/8"	5/64"	3/16"	1-RICH	
1976	231" Eng. V6 231" Eng. V6	Federal	7/16"	1 5/32"	1 19/32"	7/64"	3/32"	5/64"	9/64"	1-RICH	
		Calif.	7/16"	1 5/32"	1 19/32"	1/8"	7/64"	5/64"	9/64"	1-RICH	
		A/T	15/32"	1 5/32"	1 11/32"	9/64"	3/32"	5/64"	3/16"	1-RICH	
1977	231" Eng. V6 Carb #17057141, 145, 147	Federal	A/T	7/16"	1 5/32"	1 17/32"	7/64"	3/64"	5/64"	9/64"	3-RICH
				7/16"	1 5/32"	1 1/2"	7/64"	3/64"	5/64"	9/64"	1-RICH
	350" Eng. V8	Calif.	A/T	7/16"	1 5/32"	1 1/2"	1/8"	7/64"	5/64"	9/64"	1-RICH
		Calif.	M/T	7/16"	1 5/32"	1 1/2"	9/64"	7/64"	5/64"	9/64"	INDEX
		Altitude	A/T	7/16"	1 5/32"	1 17/32"	1/8"	7/64"	5/64"	9/64"	1-RICH
1978	196" Eng. V6 196" Eng. V6	A/T	7/16"	1 5/32"	1 19/32"	1/8"	3/64"	5/64"	9/64"	1-RICH	
		M/T	7/16"	1 5/32"	1 9/16"	7/64"	5/64"	5/64"	9/64"	1-RICH	
	231" Eng. V6 231" Eng. V6	Fed/Can	A/T	7/16"	1 5/32"	1 19/32"	7/64"	5/64"	5/64"	9/64"	1-RICH
		Federal	M/T	7/16"	1 5/32"	1 19/32"	7/64"	1/16"	5/64"	5/32"	1-RICH
	Carb #17058444 Carb #17058446 Carb #17058448	Calif.	A/T	7/16"	1 5/32"	1 19/32"	9/64"	3/32"	5/64"	9/64"	1-RICH
		Calif.	A/T	7/16"	1 5/32"	1 19/32"	1/8"	7/64"	5/64"	9/64"	1-RICH
		Calif.	A/T	7/16"	1 5/32"	1 9/16"	9/64"	3/32"	5/64"	9/64"	1-RICH
		Calif.	M/T	7/16"	1 5/32"	1 19/32"	5/32"	7/64"	5/64"	9/64"	1-RICH
		Altitude	All/T	7/16"	1 5/32"	1 19/32"	9/64"	3/32"	5/64"	9/64"	1-RICH
CHEVROLET											
1978	196" Eng. V6 196" Eng. V6	A/T	7/16"	1 5/32"	1 5/8"	7/64"	1/16"	5/64"	9/64"	1-RICH	
		M/T	7/16"	1 5/32"	1 9/16"	7/64"	5/64"	5/64"	9/64"	1-RICH	
	231" Eng. V6 231" Eng. V6	Fed/Can	A/T	7/16"	1 5/32"	1 19/32"	7/64"	5/64"	5/64"	9/64"	1-RICH
		Federal	M/T	7/16"	1 5/32"	1 19/32"	7/64"	1/16"	5/64"	5/32"	1-RICH
	231" Eng. V6 231" Eng. V6	Calif.	A/T	7/16"	1 5/32"	1 9/16"	9/64"	3/32"	5/64"	9/64"	1-RICH
		Calif.	M/T	7/16"	1 5/32"	1 19/32"	5/32"	7/64"	5/64"	9/64"	1-RICH
		Altitude	All/T	7/16"	1 5/32"	1 19/32"	9/64"	3/32"	5/64"	9/64"	1-RICH
CHEVROLET/GMC TRUCK											
1979	350" Eng. V8 w/Vac Gov	Fed/Calif.	All/T	17/32"	1 9/32"	1 15/32"	---	---	---	---	
1979-84	350" Eng. V8	Fed/Calif.	All/T	5/8"	1 9/32"	1 21/32"	---	---	---	---	
1980-82	350" Eng. V8 w/Vac Gov	Fed/Calif.	All/T	5/8"	1 9/32"	1 15/32"	---	---	---	---	
1980-84	350" Eng. V8 Carb #17080129, 17082129			5/8"	1 9/32"	1 21/32"	---	.130	.245	.250	
1985-86	350" Eng. V8 Carb #17080126 Carb #17084433, 17085126			5/8"	1 9/32"	1 15/32"	---	---	---	---	
				5/8"	1 9/32"	1 21/32"	---	---	---	---	

Year	Application		Float Level	Float Drop	Pump Rod Setting	Primary Vacuum Break	Auxiliary Vacuum Break	Choke Rod	Unloader	Automatic Choke Setting	
CHEVROLET/GMC TRUCK (Cont'd)											
1986-87	350" Eng. V8		5/8"	1 9/32"	1 15/32"	---	---	---	---	---	
	Carb #17085464, 17086059		5/8"	1 9/32"	1 21/32"	---	---	---	---	---	
1988-90	350" Eng. V8		11/16"	1 9/32"	1 9/16"	---	---	---	---	---	
	Carb #7044133	Canada	11/16"	1 9/32"	1 7/16"	---	---	---	---	---	
	Carb #17058120	Canada	5/8"	1 9/32"	1 15/32"	---	---	---	---	---	
	Carb #17088079		5/8"	1 9/32"	1 21/32"	---	---	---	---	---	
OLDSMOBILE											
1975	231" Eng. V6		7/16"	1 9/32"	1 19/32"	1/8"	1/8"	5/64"	9/64"	1-RICH	
			M/T	7/16"	1 9/32"	1 19/32"	1/8"	1/8"	5/64"	1-LEAN	
1976	350" Eng. V8		A/T	15/32"	1 9/32"	9/64"	1/8"	5/64"	3/16"	1-RICH	
	231" Eng. V6			7/16"	1 9/32"	1 19/32"	1/8"	1/8"	5/64"	1-LEXN	
	Carb #7045147, 449			7/16"	1 9/32"	1 19/32"	1/8"	1/8"	5/64"	1-RICH	
	Carb #7045149		A/T	7/16"	1 7/32"	1 19/32"	1/8"	7/64"	5/64"	1-RICH	
	Carb #7045441		A/T	7/16"	1 9/32"	1 19/32"	1/8"	7/64"	3/16"	1-RICH	
	Carb #7045447		M/T	7/16"	1 9/32"	1 19/32"	1/8"	1/8"	37/64"	1-LEAN	
	Carb #17056145, 149			7/16"	1 5/32"	1 19/32"	7/64"	3/32"	5/64"	1-RICH	
	Carb #17056447, 449			7/13"	1 5/32"	1 19/32"	1/8"	7/64"	5/64"	1-RICH	
	350" Eng. V8			15/32"	1 5/32"	1 9/16"	9/64"	7/64"	5/64"	3/16"	1-RICH
	Carb #17056143		A/T	15/32"	1 5/32"	1 5/8"	3/16"	1/32"	5/64"	3/16"	1-RICH
1977	231" Eng. V8			7/16"	1 17/32"	7/64"	3/64"	5/64"	9/64"	3-RICH	
		Federal	A/T	7/16"	1 5/32"	1 1/2"	7/64"	3/64"	5/64"	1-RICH	
			M/T	7/16"	1 5/32"	1 1/2"	7/64"	3/64"	5/64"	1-RICH	
		Calif.	A/T	7/13"	1 5/32"	1 1/2"	1/8"	7/64"	5/64"	1-RICH	
		Calif.	M/T	7/13"	1 5/32"	1 1/2"	9/64"	7/64"	5/64"	INDEX	
1978	231" Eng. V6		A/T	7/16"	1 5/32"	1 17/32"	1/8"	7/64"	5/64"	1-RICH	
		Fed/Can	A/T	7/16"	1 5/32"	1 19/32"	7/64"	5/64"	5/64"	9/64"	1-RICH
		Federal	M/T	7/16"	1 5/32"	1 19/32"	7/64"	1/16"	5/64"	5/32"	1-RICH
	Carb #17058444	Calif.	A/T	7/16"	1 5/32"	1 19/32"	9/64"	3/32"	5/64"	9/64"	1-RICH
	Carb #17058446		A/T	7/13"	1 5/32"	1 19/32"	1/8"	7/64"	5/64"	9/64"	1-RICH
	Carb #17058448		A/T	7/16"	1 5/32"	1 9/16"	9/64"	3/32"	5/64"	9/64"	1-RICH
		Calif.	M/T	7/13"	1 5/32"	1 19/32"	5/32"	7/64"	5/64"	9/64"	1-RICH
	Altitude	All/T	7/13"	1 5/32"	1 19/32"	9/64"	3/32"	5/64"	9/64"	1-RICH	
PONTIAC											
1975	350" Eng. V8		A/T	9/16"	1 7/32"	1 9/32"	9/64"	17/64"	3/32"	3/16"	1-RICH
	Carb #7045143		A/T	15/32"	1 9/32"	1 19/32"	9/64"	1/8"	5/64"	3/16"	1-RICH
	400" Eng. V8		A/T	9/13"	1 7/32"	1 11/32"	9/64"	17/64"	3/32"	3/16"	1-RICH
1976	231" Eng. V6			7/13"	1 5/32"	1 19/32"	7/64"	3/32"	5/64"	9/64"	1-RICH
		Federal		7/13"	1 5/32"	1 19/32"	1/8"	7/64"	5/64"	9/64"	1-RICH
	350" Eng. V8			15/32"	1 5/32"	1 9/16"	9/64"	7/64"	5/64"	3/16"	1-RICH
	Carb #17056143		A/T	9/13"	1 7/32"	1 11/32"	9/64"	17/64"	3/32"	3/16"	1-RICH
	Carb #7045163, 173		A/T	9/13"	1 9/32"	1 11/32"	11/64"	9/32"	3/32"	3/16"	1-RICH
	Carb #17056161, 162		A/T	9/16"	1 9/32"	1 11/32"	9/64"	9/32"	3/32"	3/16"	1-RICH
	Carb #17056163		A/T	15/32"	1 5/32"	1 5/8"	3/16"	1/32"	5/64"	3/16"	1-RICH
	Carb #17056144		A/T	9/16"	1 7/32"	1 5/16"	9/64"	5/16"	3/32"	3/16"	1-RICH
	400" Eng. V8			9/16"	1 9/32"	1 11/32"	11/64"	9/32"	3/32"	3/16"	1-RICH
	Carb #7045167		A/T	9/16"	1 9/32"	1 11/32"	11/64"	9/32"	3/32"	3/16"	1-RICH
1977	231" Eng. V6			7/16"	1 5/32"	1 17/32"	7/64"	3/64"	5/64"	9/64"	3-RICH
		Federal	A/T	7/16"	1 5/32"	1 1/2"	7/64"	3/64"	5/64"	9/64"	1-RICH
			M/T	7/16"	1 5/32"	1 1/2"	7/64"	3/64"	5/64"	9/64"	1-RICH
		Calif.	A/T	7/16"	1 5/32"	1 1/2"	1/8"	7/64"	5/64"	9/64"	1-RICH
		Calif.	M/T	7/16"	1 5/32"	1 1/2"	9/64"	7/64"	5/64"	9/64"	INDEX
1978	231" Eng. V6		A/T	7/16"	1 5/32"	1 17/32"	1/8"	7/64"	5/64"	9/64"	1-RICH
		Fed/Can	A/T	7/16"	1 5/32"	1 19/32"	7/64"	5/64"	5/64"	9/64"	1-RICH
		Federal	M/T	7/16"	1 5/32"	1 19/32"	7/64"	1/16"	5/64"	5/32"	1-RICH
	Carb #17058444	Calif.	A/T	7/16"	1 5/32"	1 19/32"	9/64"	3/32"	5/64"	9/64"	1-RICH
	Carb #17058446		A/T	7/16"	1 5/32"	1 19/32"	1/8"	7/64"	5/64"	9/64"	1-RICH
	Carb #17058448		A/T	7/16"	1 5/32"	1 19/32"	9/64"	3/32"	5/64"	9/64"	1-RICH
		Calif.	M/T	7/16"	1 5/32"	1 19/32"	5/32"	7/64"	5/64"	9/64"	1-RICH
	Altitude	All/T	7/16"	1 5/32"	1 19/32"	9/64"	3/32"	5/64"	9/64"	1-RICH	