

HOLLEY CARBURETOR MODEL 1920

I. DISASSEMBLY.

a. Disassemble in the general order of index numbers on opposite side of this sheet. Disassembly need not be carried further than indicated by the drawing except for unusual conditions. If the choke piston is not free after cleaning (indicated by resistance of choke valve movement), the welch plug at end of choke piston cylinder may be removed; the piston and cylinder cleaned thoroughly and piston replaced, if necessary.

b. Take notice of original positions and holes from which linkage rods are removed so they can be returned to the same locations during reassembly.

c. The main well and economizer assembly (19) contains the pump inlet ball and outlet ball plus the power jet assembly. These parts and internal passages will be cleaned after soaking time in the cleaning solvent and will normally be restored to good operating condition.

(DO NOT REMOVE IDLE ADJ. NEEDLE LIMITER CAP.)

II. CLEANING.

NOTE: Do not soak leather, rubber or other parts of this nature in the cleaning solvent.

Soak parts long enough to soften and remove all foreign material. Use a regular carburetor cleaning solvent, lacquer thinner, or denatured alcohol. Use a small brush to aid cleaning, if necessary. Make certain the throttle body is free of all hard carbon deposits. Blow out all passages in castings with compressed air and check carefully to insure thorough cleaning of obscure areas.

III. REASSEMBLY.

a. Reassemble the carburetor, using essentially the reverse order of disassembly.

b. Refer to paragraph 1, b, when installing linkage rods.

c. For normal operation connect the pump link in middle hole of throttle lever. For cold climates use outer hole; for hot climates use inner hole.

IV. FLOAT ADJUSTMENT. (See figure 1.)

a. Prior to installing fuel bowl, place carburetor upside-down and measure float height with the gage included in the kit. The gage should be positioned at the end of level (top) surface of float as shown.

C. A. P. = CLEAN AIR PACKAGE
C. A. S. = CLEANER AIR SYSTEM
E. C. S. = EVAPORATION CONTROL SYSTEM

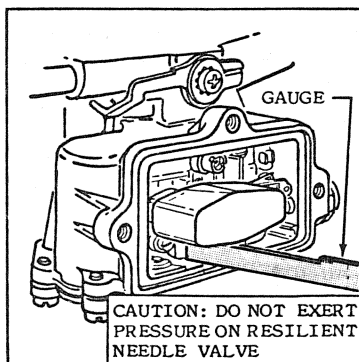

FLOAT LEVEL Fig.1

b. To adjust, bend the float tab which touches end of needle, being careful not to distort the float lever which might cause it to bind.

V. FAST IDLE CAM POSITION (1962-63 See Figure 2)

a. Hold choke valve and throttle valve closed. With carburetor in upright position, the index mark on fast-idle cam should be aligned with the center of fast-idle screw.

b. If an adjustment is required, bend the fast-idle rod, as shown, until index marks line up with screw.

c. (1964 See Figure 3.) Place fast idle screw on low step of fast idle cam and against second step. Hold choke valve toward closed position, and measure distance between upper edge of choke valve and air horn wall. To adjust bend fast idle rod. (See Data Table for measurement.) 1965-73 SECOND STEP NEXT TO HIGH STEP.

VI. IDLE ADJUSTMENT (See Figure 2)

Engine at operating temp. and choke wide open adjust idle adjusting needle to smooth idle, adjust throttle stop screw for proper R.P.M. Make adjustment with headlights and air condition on A/T in neutral. (See Data Table for R.P.M.)

VII. BOWL VENT ADJUSTMENT. (See Figure 4)

A. WITH THROTTLE AT CURB IDLE SPEED THE BOWL VENT VALVE SHOULD BE RAISED OFF ITS SEAT AS SHOWN FIG. 4
B. IF ADJUSTMENT IS REQUIRED BEND TAB AT LOCATION SHOWN. 1966-73 BEND ROD AT HORIZONTAL PORTION. 1970-73 E.C.S. MODELS CHECK CLEARANCE BETWEEN VENT VALVE STEM AND OPERATING ROD.

VIII. FAST IDLE ADJUSTMENT

1962-63 (See Figure 2) Set fast idle screw on index mark of fast idle cam and adjust to proper R.P.M.

1964-67 (See Figure 3) set fast idle screw on low step of fast idle cam and adjust to proper R.P.M. (See Data Table for R.P.M.)

1966-69 W/C. A. P. ON SECOND HIGHEST STEP.
1970-73 ALL ON SECOND HIGHEST STEP.

ADJUSTMENT DATA TABLE

BARRACUDA-DART-DODGE PLYMOUTH-VALIANT	FLOAT LEVEL	FAST IDLE CAM POSITION	SLOW IDLE R.P.M.	FAST IDLE R.P.M.
1962 EARLY MODELS WITHOUT FLOAT SPRING	9/32"	INDEX	550	1500 S/T 1700 A/T
1962-63 WITH FLOAT SPRING	3/16"	INDEX	550	1500 S/T 1700 A/T
1964 - 170" - 225" Eng.	3/16"	15/64"	550	700
1965 - 170" - 225" Eng.	3/16"	5/64"	550	700
1966-67 225" Eng.	3/16"	3/32"	550	700
1966-69 225" Eng.	3/16"	3/32"	650	1550
S/T W/C.A.P.	3/16"	1/16"	650	1550
A/T W/C.A.P.	3/16"	1/16"	700	1600
1970-71 225" Eng.	3/16"	1/16"	650	1800
All S/T	3/16"	1/16"	800	2000
All A/T	3/16"	1/16"	800	1900
1972 198" Eng. All S/T	3/16"	1/16"	750	2000
All A/T	3/16"	1/16"	750	1900
225" Eng. All S/T	3/16"	1/16"	750	1900
All A/T	9/32"	5/64"	750	1700 All A/T
1973 198" Eng. A/T	9/32"	3/32"	750	2000 All S/T
All Others	9/32"	3/32"	750	2000 All S/T
1965-71 DODGE TRUCK 170" - 225" Eng.	3/16"	---	550	---
1964-66 KAISER JEEP 6 CYL. 230" Eng.	3/16"	---	550	---

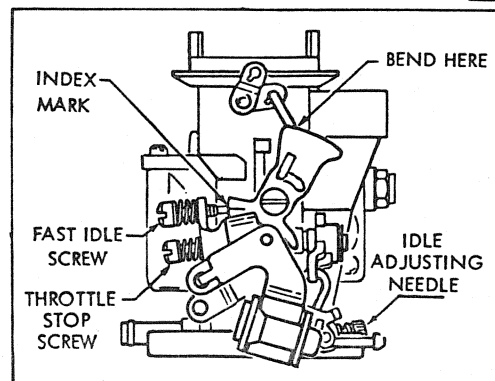

FAST IDLE CAM POSITION Fig.2

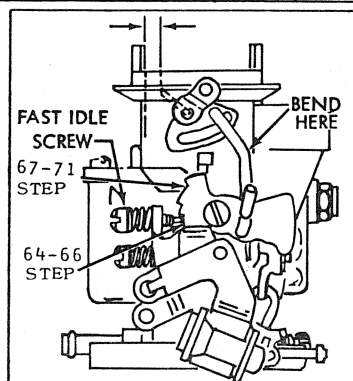

FAST IDLE CAM POSITION Fig.3

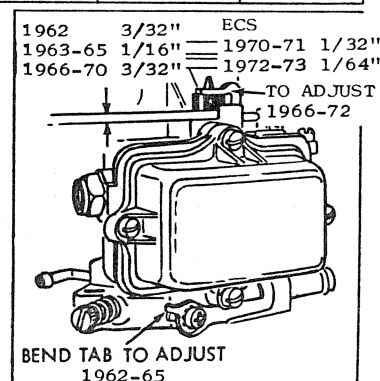

BOWL VENT ADJ. Fig.4

GENERAL EXPLODED VIEW

THE GENERAL DESIGN AND PARTS SHOWN WILL VARY TO
INDIVIDUAL UNITS COVERED ON THIS INSTRUCTION SHEET

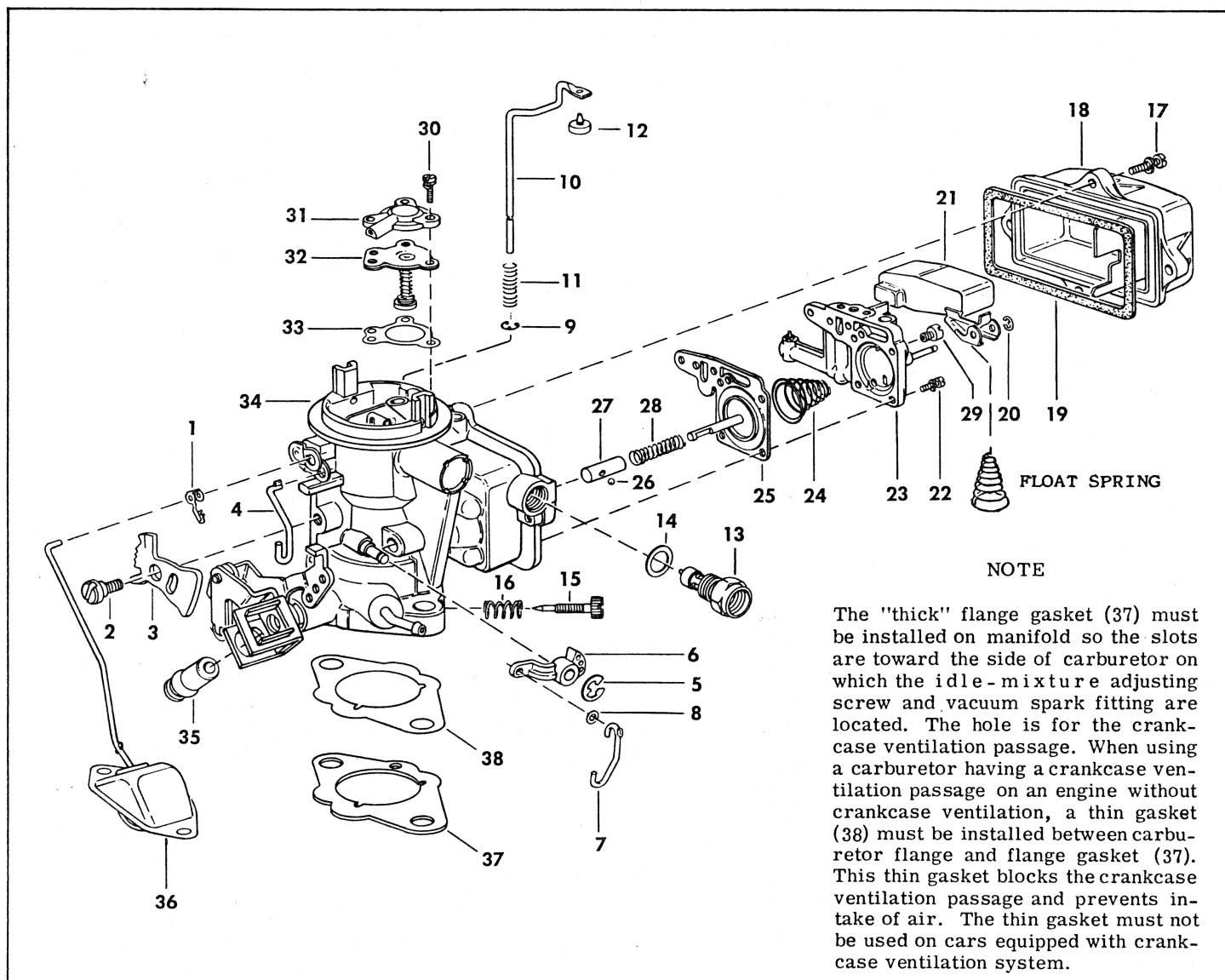

NOTE

The "thick" flange gasket (37) must be installed on manifold so the slots are toward the side of carburetor on which the idle-mixture adjusting screw and vacuum spark fitting are located. The hole is for the crankcase ventilation passage. When using a carburetor having a crankcase ventilation passage on an engine without crankcase ventilation, a thin gasket (38) must be installed between carburetor flange and flange gasket (37). This thin gasket blocks the crankcase ventilation passage and prevents intake of air. The thin gasket must not be used on cars equipped with crankcase ventilation system.

Index

No. NOMENCLATURE

1. Choke rod retainer clip
2. Fast-idle cam screw
3. Fast-idle cam
4. Fast-idle rod
5. Pump lever retainer ("E" washer)
6. Pump lever
7. Pump link
8. Pump-link washer
9. Bowl vent rod retainer ("E" washer)
10. Bowl vent rod
11. Bowl vent rod spring
12. Bowl vent valve
13. Needle and seat assembly
14. Needle seat gasket
15. Idle-mixture adjusting needle
16. Idle adjusting needle spring
17. Screw and lockwasher assembly
18. Fuel bowl
19. Fuel-bowl gasket

Index

No. NOMENCLATURE

20. Float lever retainer ("E" washer)
21. Float assembly
22. Screw and lockwasher assembly
23. Main well and economizer body assy.
24. Pump diaphragm spring
25. Pump diaphragm assembly
26. Pump push-rod sleeve ball
27. Pump push-rod sleeve
28. Pump push-rod spring
29. Main-metering jet
30. Screw and lockwasher assembly
31. Economizer diaphragm cover
32. Economizer diaphragm assembly
33. Economizer diaphragm gasket
34. Body assembly
35. Throttle-rod insulator bushing
36. Automatic choke assy. (well type)
37. Manifold flange gasket, thick (see "note", above)
38. Manifold flange gasket, thin (see "note", above)