

INSTRUCTION SHEET

(OPEL) SOLEX CARBURETOR — MODEL 32TDID-2

GENERAL EXPLODED VIEW

THE GENERAL DESIGN AND PARTS SHOWN WILL VARY TO
INDIVIDUAL UNITS COVERED ON THIS INSTRUCTION SHEET

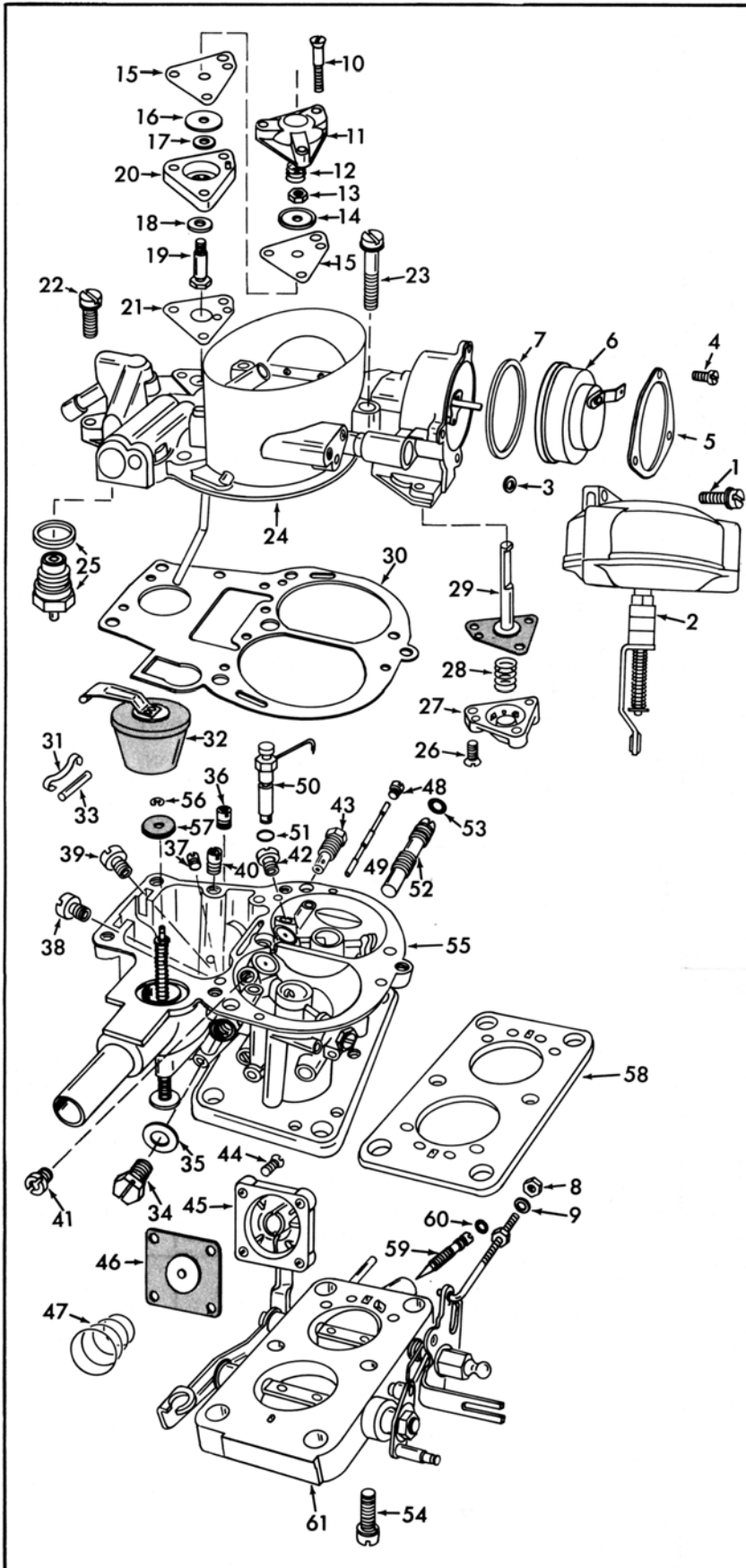

DISASSEMBLY

USE EXPLODED VIEW AS A GUIDE. THE NUMERICAL SEQUENCE MAY GENERALLY BE FOLLOWED TO DISASSEMBLE UNIT FAR ENOUGH TO PERMIT CLEANING AND INSPECTION. NOTE: TO DISCONNECT VACUUM DIAPHRAGM CASE CONNECTING LINK, PRY OFF PLASTIC RETAINER AND LINK FROM PIN, TO REMOVE INJECTOR TUBE ASSY. (50) CAREFULLY PRY UP WITH SCREWDRIVER.

NOMENCLATURE

REF. NO.	REF. NO.
1. SCREW & LOCKWASHER (2)-SEC. DIAPHRAGM ASSY.	31. RETAINER-FLOAT PIN
2. DIAPHRAGM ASSY.-SECONDARY VACUUM	32. FLOAT ASSY.
3. GASKET-SEC. DIAPHRAGM ASSY.	33. PIN-FLOAT HINGE
4. SCREW (3)-CHOKE COVER RETAINER	34. PLUG-SEC. TRANSFER PASSAGE
5. RETAINER-CHOKE COVER	35. GASKET-PLUG
6. CHOKE COVER ASSY.	36. JET-SEC. TRANSFER AIR BLEED
7. GASKET-CHOKE COVER	37. JET-SEC. TRANSFER
8. NUT-CHOKE LINK	38. JET-SEC. MAIN
9. WASHER-CHOKE LINK NUT	39. JET-PRI. MAIN
10. SCREW (3)-POWER SYSTEM COVER	40. JET-POWER SYSTEM
11. COVER-POWER SYSTEM	41. JET-SEC. AIR CORRECTION
12. SPRING-DIAPHRAGM RETURN	42. JET-PRI. AIR CORRECTION
13. NUT-DIAPHRAGM RETAINER	43. JET-PRI. IDLE
14. WASHER-DIAPHRAGM CUP	44. SCREW & LOCKWASHER (4)-PUMP COVER
15. DIAPHRAGM (2)-POWER SYSTEM	45. COVER-PUMP DIAPHRAGM
16. WASHER-DIAPHRAGM CUP	46. DIAPHRAGM ASSY.-PUMP
17. WASHER-STEM	47. SPRING-DIAPHRAGM RETURN
18. VALVE-POWER SYSTEM	48. PLUG-PUMP PASSAGE
19. STEM-POWER VALVE	49. PIN-PUMP PASSAGE
20. HOUSING-POWER VALVE	50. INJECTOR TUBE ASSY.
21. GASKET-HOUSING	51. O-RING-INJECTOR TUBE
22. SCREW & LOCKWASHER (1)-BOWL COVER	52. SCREW-IDLE AIR SPEED ADJ.
23. SCREW & LOCKWASHER (4)-BOWL COVER	53. O-RING-IDLE SPEED SCREW
24. BOWL COVER ASSY.	54. SCREW & LOCKWASHER (2)-THROTTLE BODY TO BOWL
25. NEEDLE SEAT & GASKET ASSY.	55. BOWL ASSY.
26. SCREW (3)-DIAPHRAGM COVER	56. E-CLIP-VENT VALVE
27. COVER-DIAPHRAGM	57. VALVE-BOWL VENT
28. SPRING-DIAPHRAGM RETURN	58. GASKET-THROTTLE BODY
29. DIAPHRAGM ASSY.-VACUUM BREAK	59. NEEDLE-IDLE ADJ.
30. GASKET-BOWL COVER	60. O-RING-IDLE NEEDLE
	61. THROTTLE BODY ASSY.

CLEANING

CLEANING MUST BE DONE WITH CARBURETOR DISASSEMBLED. SOAK PARTS LONG ENOUGH TO SOFTEN AND REMOVE ALL FOREIGN MATERIAL. USE A CARBURETOR CLEANING SOLVENT. MAKE CERTAIN THE THROTTLE BODY IS FREE OF ALL CARBON DEPOSITS. WASH OFF IN SUITABLE SOLVENT. BLOW OUT ALL PASSAGES IN CASTINGS WITH COMPRESSED AIR AND CHECK CAREFULLY TO INSURE THOROUGH CLEANING OF OBSCURE AREAS. CAUTION: DO NOT SOAK DIAPHRAGM ASSY. (2) ELECTRIC CHOKE COVER (6) FLOAT (32) OR PARTS MADE OF RUBBER MATERIAL IN CLEANING SOLVENTS.

REASSEMBLY

REASSEMBLE IN REVERSE ORDER OF DISASSEMBLY. NOTE SPECIAL INSTRUCTIONS AND ADJUSTMENTS.

SPECIAL INSTRUCTIONS

IDLE ADJUSTING NEEDLE (59)-TURN IN UNTIL LIGHTLY BOTTOMED THEN BACK OUT 5 TURNS.

IDLE AIR SPEED SCREW (52)-TURN IN UNTIL LIGHTLY BOTTOMED THEN BACK OUT 3 1/2 TURNS.

INJECTOR TUBE ASSY (50)-INSTALL ASSY. WITH NOZZLE POINTING INTO PRIMARY VENTURI.

PUMP SPRING (47)-INSTALL WITH SMALL END TOWARD DIAPHRAGM.

VACUUM BREAK DIAPHRAGM SPRING (28)-IS SHORTER THAN POWER SYSTEM DIAPHRAGM SPRING (12).

CHOKE COVER ASSY. (6)-INSTALL SO THAT THE CATCH OF THE BI-METAL SPRING IS POSITIONED ONTO BENT END OF THE INTERMEDIATE LEVER. ALIGN MARK ON COVER WITH CENTER POINT ON HOUSING (INDEX SETTING).

ADJUSTMENTS

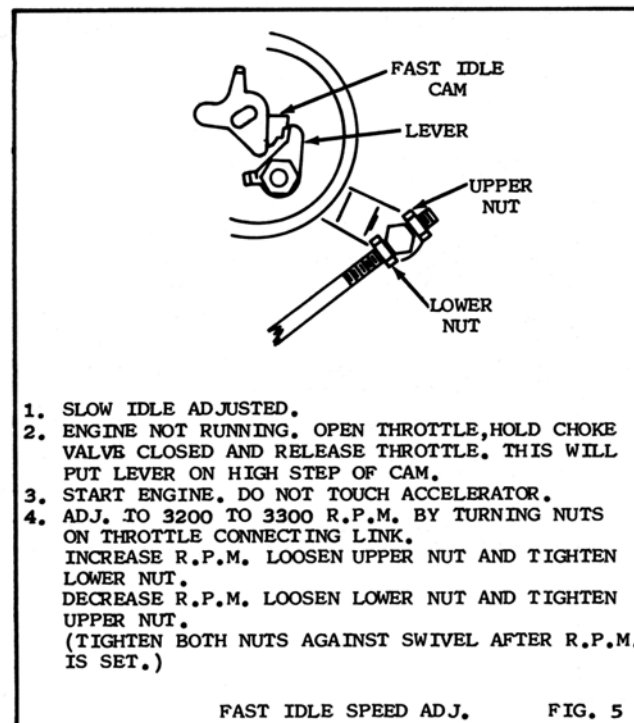
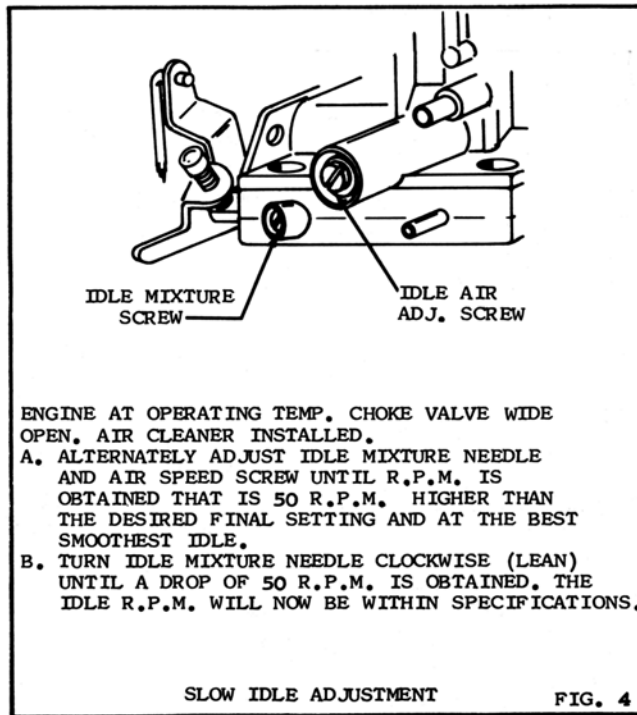
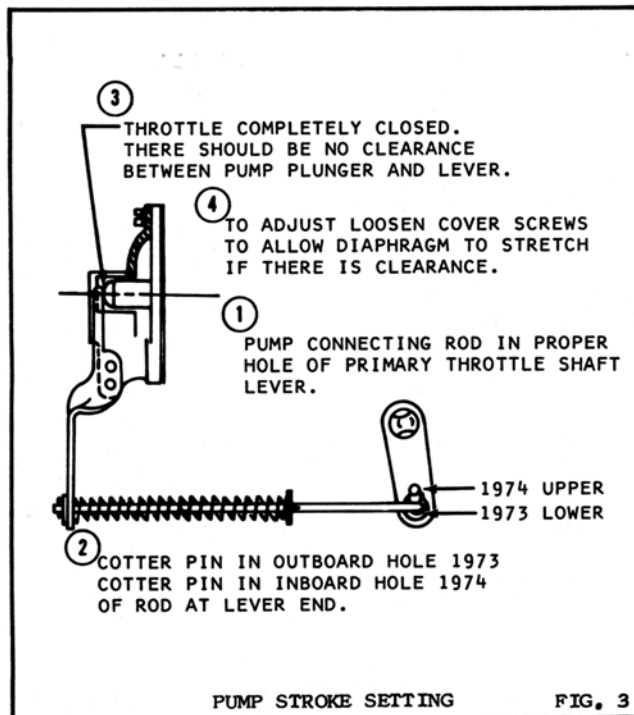
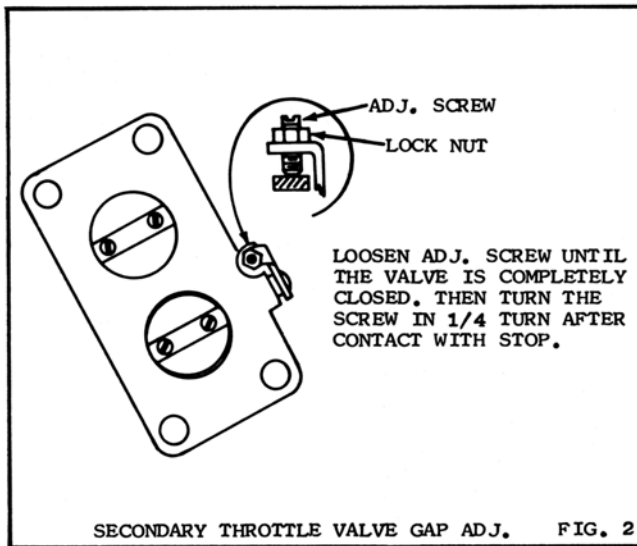
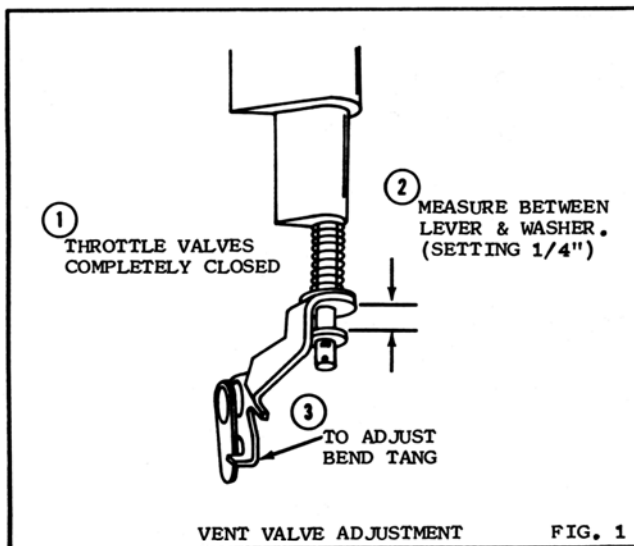

JET INSTALLATION

	1973 OPEL 1900 & MANTA	1973 GT	1974 MANTA
MAIN JETS			
PRIMARY	X122.5	X120	X125
SECONDARY	X155	X137.5	X160
AIR CORRECTION JETS			
PRIMARY	120	110	130
SECONDARY	80	120	80