

INSTRUCTION SHEET

HITACHI CARBURETOR- MODEL DRJ 340

LUV TRUCK SERIES 1,2,3,

50-436-2

DISASSEMBLY

GENERAL EXPLODED VIEW

THE GENERAL DESIGN AND PARTS SHOWN WILL VARY TO INDIVIDUAL UNITS COVERED ON THIS INSTRUCTION SHEET.

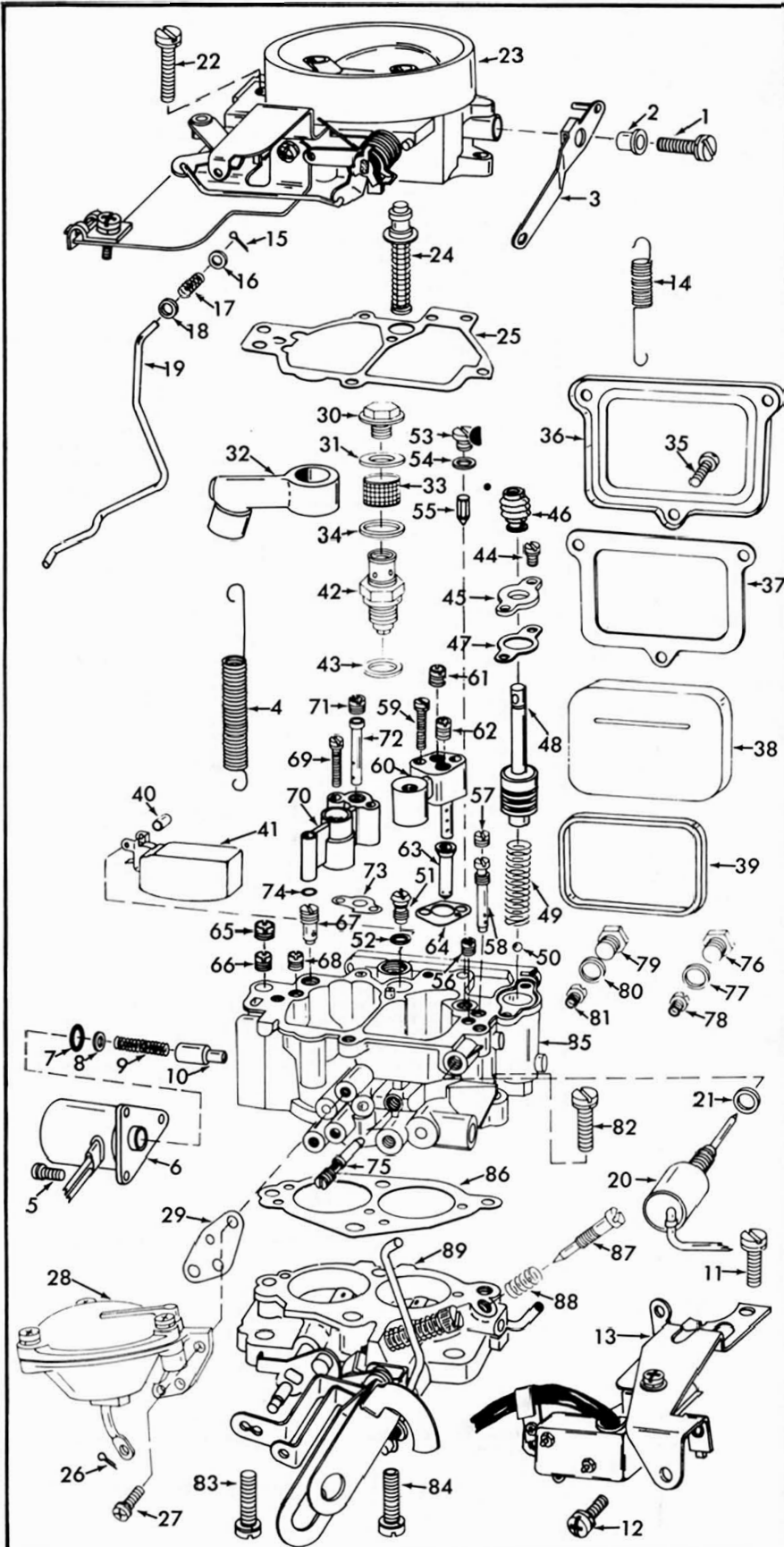

USE EXPLODED VIEW AS A GUIDE. THE NUMERICAL SEQUENCE MAY GENERALLY BE FOLLOWED TO DISASSEMBLE UNIT FAR ENOUGH TO PERMIT CLEANING AND INSPECTION. BEING CAREFUL WITH THE COASTING VALVE SOLENOID (6), THROTTLE SWITCH & BRACKET (13), ANTI DIESELING SOLENOID (20). AS THE LOOM IS NOT MADE TO SEPARATE WILL STAY TOGETHER AS A UNIT. REMOVE STAKING FROM AIR HORN FOR EASY REMOVAL OF POWER PISTON ASSY. **BE CAREFUL** TO NOTE SIZES OF ALL JETS AND THEIR LOCATION FOR PROPER ASSEMBLY. RECORD SIZES BELOW.

NOMENCLATURE

REF. NO.	REF. NO.
1. SCREW & LOCKWASHER - PUMP LEVER	45. PLATE - PUMP BOOT - PUMP
2. SLEEVE - PUMP LEVER	46. GASKET - PUMP PLATE
3. LEVER - PUMP	47. PUMP ASSY.
4. SPRING - THROTTLE RETURN	48. SPRING - PUMP RETURN
5. SCREW & LOCKWASHER (3) - SOLENOID	49. BALL (NYLON) - PUMP INTAKE CHECK
6. SOLENOID - COASTING VALVE	51. POWER VALVE ASSY.
7. O-RING - SOLENOID	52. GASKET - POWER VALVE
8. WASHER - SHIM	53. PLUG - PUMP DISC. NEEDLE
9. SPRING - VALVE	54. GASKET - PLUG
10. VALVE - COASTING	55. NEEDLE - PUMP DISC.
11. SCREW & LOCKWASHER - SWITCH BRACKET	56. JET - PRI. SLOW AIR BLEED
12. SCREW & LOCKWASHER - SWITCH BRACKET	57. PLUG - PRI. SLOW JET
13. THROTTLE SWITCH AND BRACKET ASSY.	58. JET - PRI. SLOW
14. SPRING - SEC. THROTTLE RETURN	59. SCREW & WASHERS (2) - PRI. VENTURI
15. COTTER PIN - FAST IDLE ROD	60. PRI. VENTURI ASSY.
16. WASHER - FAST IDLE ROD	61. JET - PRI. MAIN AIR BLEED
17. SPRING - FAST IDLE ROD	62. JET - ACCELERATOR AIR BLEED
18. WASHER - FAST IDLE ROD	63. TUBE - PRI. EMULSION
19. ROD - FAST IDLE	64. GASKET - PRI. VENTURI
20. SOLENOID - ANTI DIESELING	65. JET - COASTING AIR BLEED
21. GASKET - SOLENOID	66. JET - COASTING
22. SCREW & LOCKWASHER (3) - AIR HORN	67. JET - SEC. SLOW
23. AIR HORN ASSY.	68. JET - SEC. SLOW AIR BLEED
24. POWER PISTON ASSY.	69. SCREW & WASHERS (3) - SEC. VENTURI
25. GASKET - AIR HORN	70. SEC. VENTURI ASSY.
26. COTTER PIN - SEC. DIAPHRAGM LINK	71. JET - SEC. MAIN AIR BLEED
27. SCREW & LOCKWASHER (3) - SEC. DIAPHRAGM ASSY.	72. TUBE - SEC. EMULSION
28. SEC. DIAPHRAGM ASSY.	73. GASKET - SEC. VENTURI
29. GASKET - SEC. DIAPHRAGM ASSY.	74. GASKET - SEC. VENTURI
30. BOLT - FUEL INLET NIPPLE	75. JET - VACUUM
31. GASKET - NIPPLE	76. PLUG - PRI. MAIN JET
32. NIPPLE - FUEL INLET	77. GASKET - PLUG
33. SCREEN - FUEL INLET	78. JET - PRI. MAIN
34. GASKET - NIPPLE	79. PLUG - SEC. MAIN JET
35. SCREW (3) - LEVEL GAUGE COVER	80. GASKET - PLUG
36. COVER - LEVEL GAUGE	81. JET - SEC. MAIN
37. GASKET - LEVEL GAUGE COVER	82. SCREW & LOCKWASHER - THROTTLE BODY
38. GAUGE - LEVEL	83. SCREW & LOCKWASHER (2) - THROTTLE BODY
39. SEAL - LEVEL GAUGE	84. SCREW & LOCKWASHER (1) - THROTTLE BODY (HOLLOW) BOWL ASSY.
40. COLLAR - FLOAT	85. GASKET - THROTTLE BODY
41. FLOAT & LEVER ASSY.	87. NEEDLE - IDLE ADJ.
42. NEEDLE & SEAT ASSY.	88. SPRING - IDLE NEEDLE
43. GASKET (SERVICE) - NEEDLE & SEAT	89. THROTTLE BODY ASSY.
44. SCREW & LOCKWASHER (2) - PUMP PLATE	

CLEANING

CLEANING MUST BE DONE WITH CARBURETOR DISASSEMBLED. SOAK PARTS LONG ENOUGH TO SOFTEN AND REMOVE ALL FOREIGN MATERIAL. USE A CARBURETOR CLEANING SOLVENT. MAKE CERTAIN THE THROTTLE BODY IS FREE OF ALL CARBON DEPOSITS. WASH OFF IN SUITABLE SOLVENT. BLOW OUT ALL PASSAGES IN CASTINGS WITH COMPRESSED AIR AND CHECK CAREFULLY TO INSURE THOROUGH CLEANING OF OBSCURE AREAS. CAUTION: DO NOT SOAK RUBBER PARTS, SOLENOIDS, DIAPHRAGM UNITS OR FLOAT IN ANY TYPE OF SOLVENTS.

REASSEMBLY

REASSEMBLE IN REVERSE ORDER OF DISASSEMBLY. NOTE: SPECIAL INSTRUCTIONS AND ADJUSTMENTS.

SPECIAL INSTRUCTIONS

- IDLE ADJUSTING NEEDLE (87) - TURN NEEDLE IN UNTIL LIGHTLY SEATED THEN BACK OUT 3 1/2 TURNS.
- PUMP RETURN SPRING (49) - INSTALL WITH CROSS WIRE IN SLOT AT BOTTOM OF PUMP CYLINDER.
- NEEDLE & SEAT (42) - INSTALL GASKET (43) ON SERVICE NEEDLE & SEAT.
- LEVEL GAUGE COVER SCREWS (35) - TIGHTEN SCREWS DOWN EVENLY DON'T OVERTIGHTEN.
- POWER PISTON (24) - AFTER INSTALLATION LIGHTLY RESTAKE CASTING AROUND WASHER.

INSTRUCTION SHEET

HITACHI CARBURETOR- TYPE DCH 340

LUV TRUCK SERIES 9

GENERAL EXPLODED VIEW

THE GENERAL DESIGN AND PARTS SHOWN WILL VARY TO INDIVIDUAL UNITS COVERED ON THIS INSTRUCTION SHEET.

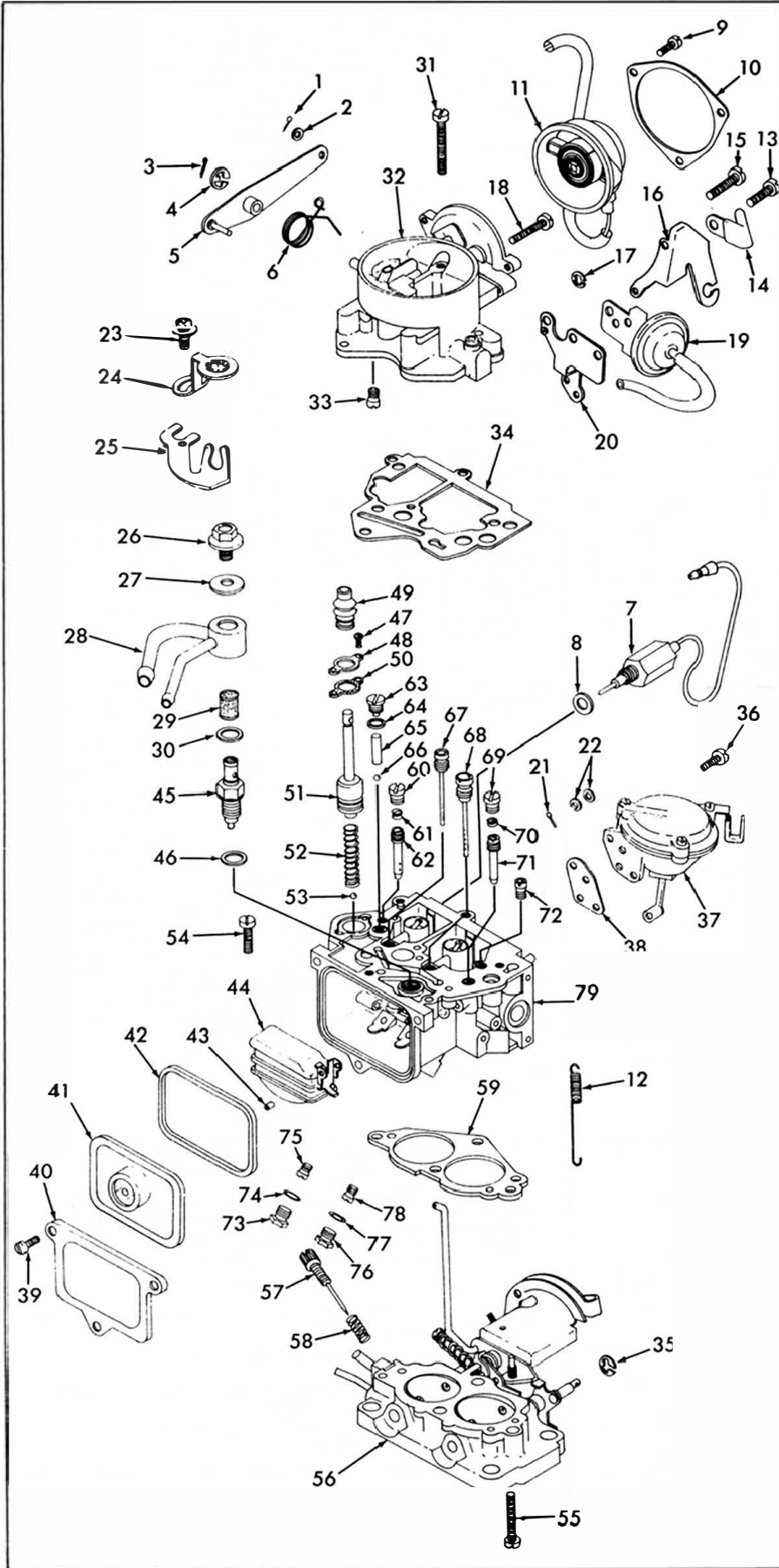

DISASSEMBLY

USE THE EXPLODED VIEW AS A GUIDE. THE NUMERICAL SEQUENCE MAY GENERALLY BE FOLLOWED TO DISASSEMBLE UNIT FAR ENOUGH TO PERMIT CLEANING AND INSPECTION. CAUTION: BE CAREFUL TO NOTE SIZES OF ALL JETS AND THEIR LOCATION FOR PROPER ASSEMBLY. RECORD SIZES BELOW.

NOMENCLATURE

REF. NO.	REF. NO.
1. COTTER PIN- PUMP ROD	39. SCREW (3)- COVER
2. WASHER- PUMP ROD	40. COVER- LEVEL GAUGE
3. COTTER PIN- PUMP LEVER PIN	41. GAUGE- LEVEL
4. RETAINER- PUMP LEVER	42. SEAL- LEVEL GAUGE
5. LEVER- PUMP	43. COLLAR- FLOAT
6. SPRING- PUMP LEVER	44. FLOAT & LEVEL ASSY.
7. SOLENOID ASSY.- ANTI DIESELING	45. NEEDLE & SEAT ASSY.
8. GASKET- SOLENOID	46. GASKET (SERVICE)- NEEDLE SEAT
9. SCREW (3)- RETAINER	47. SCREW & LOCKWASHER (2)- PUMP PLATE.
10. RETAINER- CHOKE COVER	48. PLATE- PUMP
11. CHOKE COVER ASSY.- ELECTRIC	49. BOOT- PUMP
12. SPRING- SEC. THROTTLE RETURN LEVER.	50. GASKET- PUMP PLATE
13. SCREW & LOCKWASHER- CLAMP & BRACKET.	51. PUMP ASSEMBLY
14. CLAMP- WIRE	52. SPRING- PUMP RETURN
15. SCREW & LOCKWASHER- BRACKET	53. BALL (METAL)- PUMP INTAKE CHECK
16. BRACKET- CABLE	54. SCREW & LOCKWASHER- THROTTLE BODY.
17. RETAINER- VACUUM BREAK LINK	55. SCREW & LOCKWASHER(3)- THROTTLE BODY.
18. SCREW & LOCKWASHER- CHOKE HOUSING.	56. THROTTLE BODY ASSY.
19. VACUUM BREAK & HOSE ASSY.	57. NEEDLE- IDLE ADJUSTING
20. BRACKET- SEC. RETURN SPRING	58. SPRING- IDLE ADJ. NEEDLE
21. COTTER PIN- FAST IDLE ROD	59. GASKET- THROTTLE BODY
22. WASHER (2)- FAST IDLE ROD	60. PLUG- PRI. SLOW JET
23. SCREW. LOCK & FLAT WASHER- CLAMP.	61. SPRING- PRI. SLOW JET
24. LOCK- BANJO BOLT	62. JET- PRI SLOW
25. BRACKET- BANJO	63. PLUG- PUMP DISC. BALL
26. BOLT- BANJO	64. GASKET- PLUG
27. WASHER- BANJO BOLT (UPPER)	65. WEIGHT- PUMP DISC. BALL
28. BANJO- FUEL INLET	66. BALL- PUMP DISC (METAL)
29. SCREEN- FUEL INLET	67. JET- PRI. MAIN AIR BLEED
30. WASHER- BANJO (LOWER)	68. JET- SEC. MAIN AIR BLEED
31. SCREW & LOCKWASHER (3)- AIR HORN	69. PLUG- SEC. SLOW JET
32. AIR HORN ASSEMBLY	70. SPRING- SEC. SLOW JET
33. JET- PRI. SLOW AIR BLEED	71. JET- SEC. SLOW
34. GASKET- AIR HORN	72. JET- AIR BLEED
35. RETAINER- SEC. DIAPH. LINK	73. PLUG- PRI. MAIN JET
36. DIAPHRAGM ASSEMBLY.	74. GASKET- PLUG
37. SEC. DIAPHRAGM ASSY.	75. JET- PRI. MAIN
38. GASKET- SEC DIAPH. ASSY	76. PLUG- SEC. MAIN JET
	77. GASKET- PLUG
	78. JET- SEC. MAIN
	79. BOWL ASSEMBLY

CLEANING

CLEANING MUST BE DONE WITH CARBURETOR DISASSEMBLED. SOAK PARTS LONG ENOUGH TO SOFTEN AND REMOVE ALL FOREIGN MATERIAL. USE A CARBURETOR CLEANING SOLVENT. MAKE CERTAIN THE THROTTLE BODY IS FREE OF ALL CARBON DEPOSITS. WASH OFF IN SUITABLE SOLVENT BLOW OUT PASSAGES IN CASTINGS WITH COMPRESSED AIR AND CHECK CAREFULLY FOR CLEANING OF OBSCURE AREAS. CAUTION: DO NOT SOAK RUBBER PARTS, SOLENOID (7); DIAPHRAGM UNITS (19)-(37); FLOAT (44), OR ELECTRIC CHOKE COVER ASSY. (11) IN ANY TYPE OF CLEANING SOLVENT.

REASSEMBLY

REASSEMBLE IN REVERSE ORDER OF DISASSEMBLY NOTE SPECIAL INSTRUCTIONS AND ADJUSTMENTS

SPECIAL INSTRUCTIONS

IDLE ADJUSTING NEEDLE (57)- TURN NEEDLE IN UNTIL LIGHTLY SEATED THEN BACK OUT 2 TO 3 TURNS

NEEDLE & SEAT (45)- INSTALL GASKET (46)- ON SERVICE NEEDLE AND SEAT BEFORE INSTALLING.

LEVEL GAUGE COVER SCREWS (39)- TIGHTEN SCREWS DOWN EVENLY (DO NOT OVER TIGHTEN)

INSTRUCTION SHEET

HITACHI CARBURETOR- MODEL DCP 340

LUV TRUCK SERIES 4,5,6,8

GENERAL EXPLODED VIEW

THE GENERAL DESIGN AND PARTS SHOWN WILL VARY TO
INDIVIDUAL UNITS COVERED ON THIS INSTRUCTION SHEET.

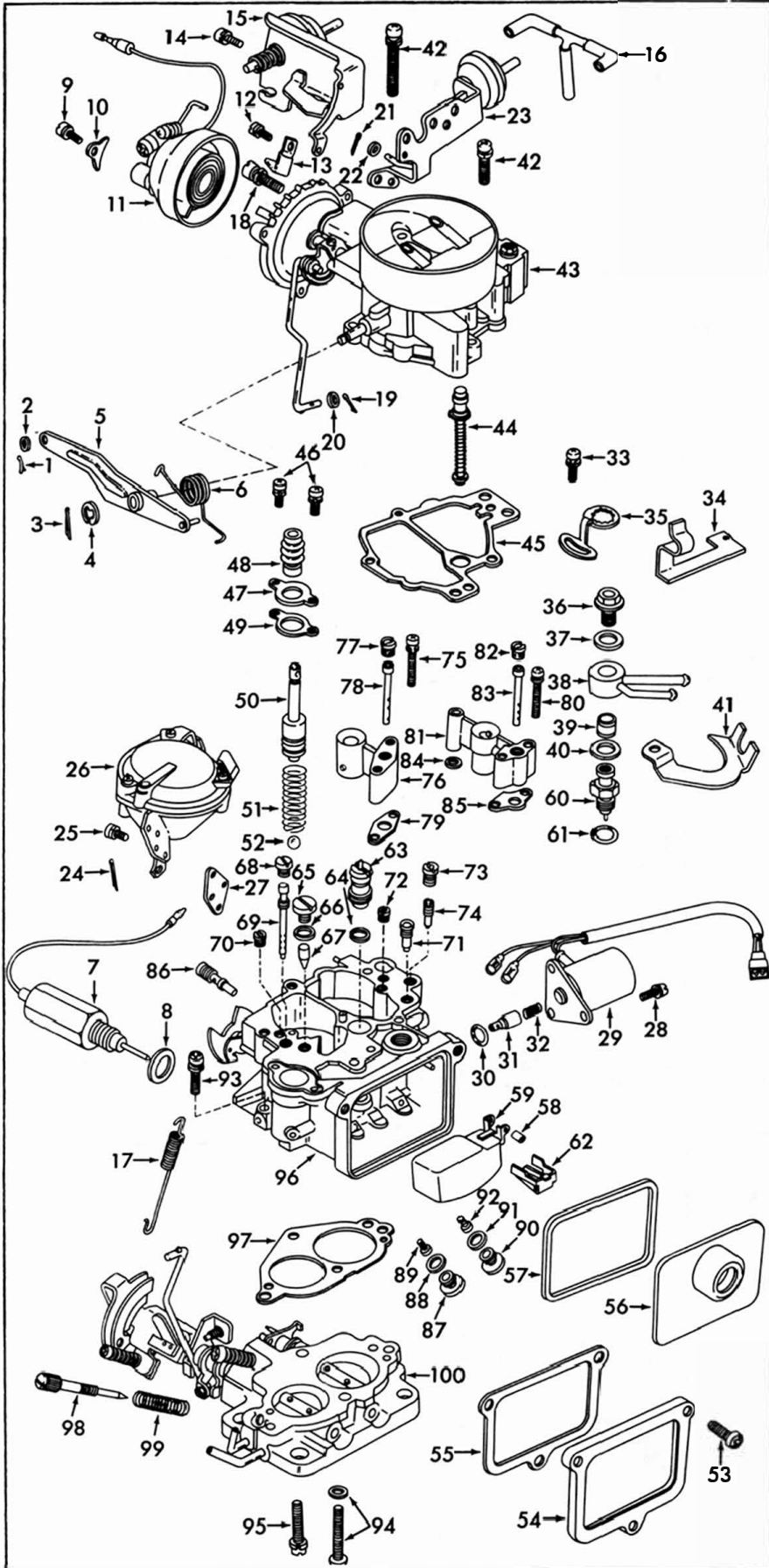

DISASSEMBLY

USE EXPLODED VIEW AS A GUIDE. THE NUMERICAL SEQUENCE MAY GENERALLY BE FOLLOWED TO DISASSEMBLE UNIT FAR ENOUGH TO PERMIT CLEANING AND INSPECTION. REMOVE STAKING FROM AIR HORN FOR EASY REMOVAL OF POWER PISTON ASSY. (44). BE CAREFUL TO NOTE SIZES OF ALL JETS AND THEIR LOCATION FOR PROPER ASSEMBLY. RECORD SIZES BELOW.

NOMENCLATURE

REF. NO.	REF. NO.
1. COTTER PIN-PUMP ROD	50. PUMP ASSY.
2. WASHER-PUMP ROD	51. SPRING-PUMP RETURN
3. COTTER PIN-PUMP LEVER PIN	52. BALL(NYLON)-PUMP INTAKE CHECK
4. RETAINER-PUMP LEVER	53. SCREW(3)-COVER
5. LEVER-PUMP	54. COVER-LEVEL GAUGE
6. SPRING-PUMP LEVER	55. GASKET-COVER
7. SOLENOID ASSY.-ANTI-DIESELING	56. GAUGE-LEVEL
8. GASKET-SOLENOID	57. SEAL-LEVEL GAUGE
9. SCREW(3)-RETAINER	58. COLLAR-FLOAT
10. RETAINER(3)-CHOKE COVER	59. FLOAT & LEVER ASSY.
11. ELECTRIC CHOKE COVER ASSY.	60. NEEDLE & SEAT ASSY.
12. SCREW & LOCKWASHER-CLAMP & BRACKET	61. GASKET(SERVICE)-NEEDLE SEAT
13. CLAMP-WIRE	62. CLIP-FUEL SHIELD
14. SCREW & LOCKWASHER-BRACKET	63. POWER VALVE
15. VACUUM BREAK ASSY.-AUXILIARY	64. GASKET-POWER VALVE
16. HOSE ASSY.-VACUUM BREAK UNITS	65. PLUG-PUMP DISC. NEEDLE
17. SPRING-SEC. THROTTLE RETURN LEVER	66. GASKET-PLUG
18. SCREW & LOCKWASHER-CHOKE HOUSING	67. NEEDLE-PUMP DISC.
19. COTTER PIN-FAST IDLE ROD	68. PLUG-PRI. SLOW JET
20. WASHER(2)-FAST IDLE ROD	69. JET-PRI. SLOW
21. COTTER PIN-VACUUM BREAK DIAPHRAGM LINK	70. JET-PRI. SLOW AIR BLEED
22. WASHER(2)-VACUUM BREAK DIAPHRAGM LINK	71. JET-SEC. SLOW
23. VACUUM BREAK ASSY.-MAIN	72. JET-SEC. SLOW AIR BLEED
24. COTTER PIN-SEC. DIAPHRAGM ASSY. LINK	73. JET-DECELERATION AIR BLEED
25. SCREW & LOCKWASHER(3)-SEC. DIAPHRAGM ASSY.	74. JET-DECELERATION
26. SECONDARY DIAPHRAGM ASSY.	75. SCREW & LOCKWASHER(2)-PRI. VENTURI
27. GASKET-SEC. DIAPHRAGM ASSY.	76. PRI. VENTURI ASSY.
28. SCREW & LOCKWASHER (3)-SOLENOID	77. JET-PRI. AIR BLEED
29. SOLENOID ASSY.--COASTING VALVE	78. TUBE-PRI. EMULSION (SOLID END)
30. O-RING-SOLENOID	79. GASKET-PRI. VENTURI
31. VALVE-COASTING	80. SCREW & WASHERS(3)-SEC. VENTURI
32. SPRING-COASTING VALVE	81. SEC. VENTURI ASSY.
33. SCREW & LOCKWASHER-CLAMP	82. JET-SEC. AIR BLEED
34. CLAMP BRACKET	83. TUBE-SEC. EMULSION (OPEN END)
35. LOCK-BANJO BOLT	84. GASKET-SEC. VENTURI
36. BOLT-BANJO	85. GASKET-SEC. VENTURI
37. WASHER-BANJO BOLT(UPPER)	86. JET-VACUUM
38. BANJO-FUEL INLET	87. PLUG-PRI. MAIN JET
39. SCREEN-FUEL INLET	88. GASKET-PLUG
40. WASHER-BANJO(LOWER)	89. JET-PRI. MAIN
41. BRACKET-BANJO	90. PLUG-SEC. MAIN JET
42. SCREW & LOCKWASHER(3)-AIR HORN	91. GASKET-PLUG
43. AIR HORN ASSY.	92. JET-SEC. MAIN
44. POWER PISTON ASSY.	93. SCREW & LOCKWASHER-THROTTLE BODY
45. GASKET-AIR HORN	94. SCREW & LOCKWASHER-THROTTLE BODY(HOLLOW)
46. SCREW & LOCKWASHER(2)-PUMP PLATE	95. SCREW & LOCKWASHER(2)-THROTTLE BODY
47. PLATE-PUMP	96. BOWL ASSY.
48. BOOT-PUMP	97. GASKET-THROTTLE BODY
49. GASKET-PUMP PLATE	98. NEEDLE-IDLE ADJUSTING
	99. SPRING-IDLE ADJ. NEEDLE
	100. THROTTLE BODY ASSY.

CLEANING

CLEANING MUST BE DONE WITH CARBURETOR DISASSEMBLED. SOAK PARTS LONG ENOUGH TO SOFTEN AND REMOVE ALL FOREIGN MATERIAL. USE A CARBURETOR CLEANING SOLVENT. MAKE CERTAIN THE THROTTLE BODY IS FREE OF ALL CARBON DEPOSITS. WASH OFF IN SUITABLE SOLVENT. BLOW OUT ALL PASSAGES IN CASTINGS WITH COMPRESSED AIR AND CHECK CAREFULLY TO INSURE THOROUGH CLEANING OF OBSCURE AREAS. CAUTION: DO NOT SOAK RUBBER PARTS (16), (48), (56); SOLENOIDS (7), (29); DIAPHRAGM UNITS (15), (23), (26); FLOAT (59); OR ELECTRIC CHOKE COVER ASSY. (11) IN ANY TYPE OF CLEANING SOLVENT.

REASSEMBLY

REASSEMBLE IN REVERSE ORDER OF DISASSEMBLY,NOTE: SPECIAL INSTRUCTIONS AND ADJUSTMENTS.

SPECIAL INSTRUCTIONS

IDLE ADJUSTING NEEDLE (98)-- TURN NEEDLE IN UNTIL LIGHTLY SEATED THEN BACK OUT 2-3 TURNS.

NEEDLE AND SEAT (60)--INSTALL GASKET (61) ON SERVICE NEEDLE AND SEAT BEFORE INSTALLING.

LEVEL GAUGE COVER SCREWS (53)-- TIGHTEN SCREWS DOWN EVENLY (DON'T OVERTIGHTEN).

POWER PISTON (44)-- AFTER INSTALLATION LIGHTLY RESTAKE CASTING AROUND WASHER.

ADJUSTMENTS

